

# **OPERATION MANUAL**

---

---

**MODEL 6250/6219 SERIES  
MICRO COMPUTER BASED  
PH/mV/ION/TEMP METER**

**JENCO** ELECTRONICS, LTD.  
MANUFACTURER OF PRECISION INSTRUMENTS

## **General Description**

The bench type model 6219 and portable type model 6250 pH/mV/Ion/TEMP meter are precise instrument for the measurement of pH, mV, ion and temperature.

A built in micro computer stores, calculates and compensates for all the relevant parameters relating to pH determinations, such as the temperature characteristics of the pH electrode, buffer solutions and electrode slope deviations, etc.

This two models can measure specific ion concentration directly in the ION mode. The ION mode provides a digital readout in any concentration units.

The RESOL. key can select different resolution of pH and mV measurements.

Additional features such as splash proof touch keys with audio feedback, buffer recognition, electrode slope recognition, ATC (Automatic Temperature Compensation) capabilities, temperature measurement to 0.1 degree C, visual and audio operational error indications, simplicity of operations, large LCD display can display pH (mV/ion) and temperature values of the sample simultaneously., etc., make the 6219 and 6250 ideal "USER FRIENDLY" instruments for field (model 6250) or laboratory (model 6219) applications.

The instrument is powered by six AA-size (model 6219) / AAA-size (model 6250) alkaline batteries or AC adaptor. When the batteries are in need of replacement, the LCD will display a "LO BAT" message.

## **Initial Inspection**

Carefully unpack the instrument and accessories. Inspect for damage in shipment. If any damage is found, notify your JENCO representative immediately. All packing materials should be saved until satisfactory

operation is confirmed.

The model 6250 and model 6219 are used 4.01pH, 7.00pH and 10.01pH standard buffer. The model 6250C and model 6219C are used 4.00pH, 6.86pH and 9.18pH standard buffer. Make sure the model number is that you ordered.

## **POWER SOURCE**

The Jenco model 6250 operate on either six AAA size alkaline batteries or AC adaptor. The model 6219 operate on either six AA size alkaline batteries or AC adaptor. Insert batteries as described below.

## **BATTERY INSTALLATION**

1. Replace batteries when the LOBAT annicator on the LCD display starts to flash. The meter can operate within specifications for approximately one hour after LOBAT starts to flash. But you must replace the new batteries when OFF is display, ie. automatic turn OFF to prevent incorrect measurements.
2. A Open battery compartment by pushing closure up. This is most easily open by using a coin (such as a penny) and inserting it into the slot on the side of the meter. (model 6250)
2. B Open battery compartment by pushing closure up and lift the battery cover to expose the battery compartment.(model 6219)
3. Insert the batteries and ensure polarity is correct as shown in **Figure 1**.
4. Replace battery compartment cover.

## **TURN OFF INSTRUMENT**

When the instrument is not in use, press the ON/OFF or POWER key to turn off the instrument. Un-plugging the AC adaptor from the instrument or from the AC line does not turn off the instrument. It would automatically switch to the internal batteries. The instrument will continue to operate on the internal batteries.

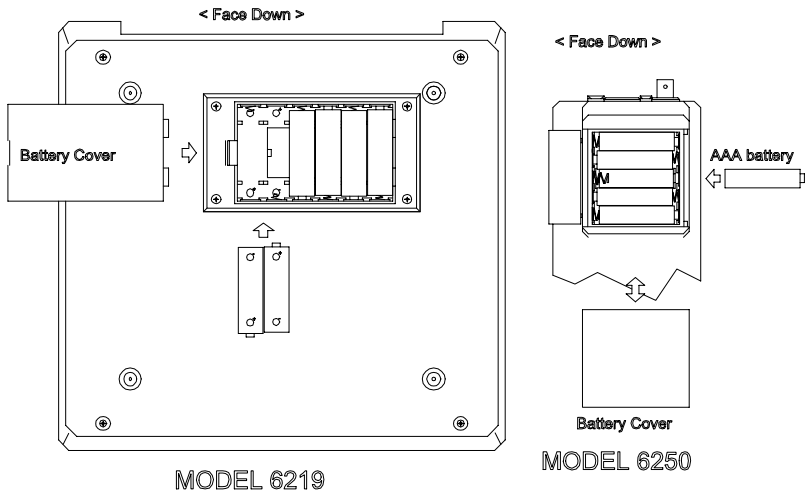
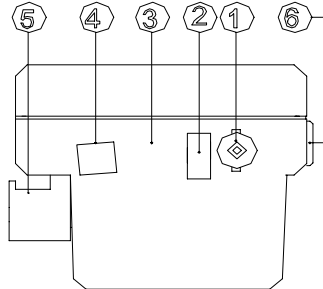

Figure 1 Battery Compartment

# MODEL 6250



1. pH BNC CONNECTOR
2. REF ELECTRODE INPUT CONNECTOR
3. ATC INPUT CONNECTOR
4. AC ADAPTOR INPUT CONNECTOR
5. ELECTRODE HOLDER
6. RS-232C CONNECTOR

# MODEL 6219

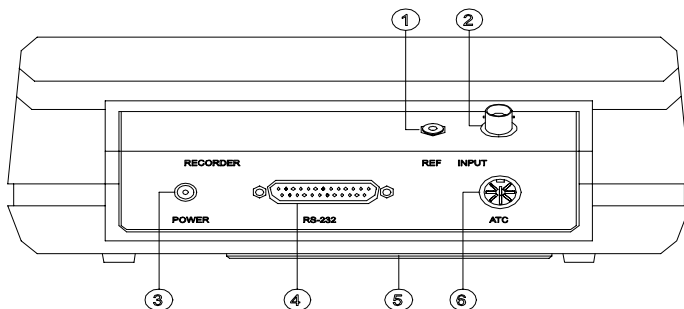

1. REF INPUT CONNECTOR
2. pH BNC INPUT CONNECTOR
3. AC ADAPTOR INPUT CONNECTOR
4. RS-232C CONNECTOR
5. BATTERY COMPARTMENT
6. ATC INPUT CONNECTOR

Figure 2 rear view of model 6250/6219

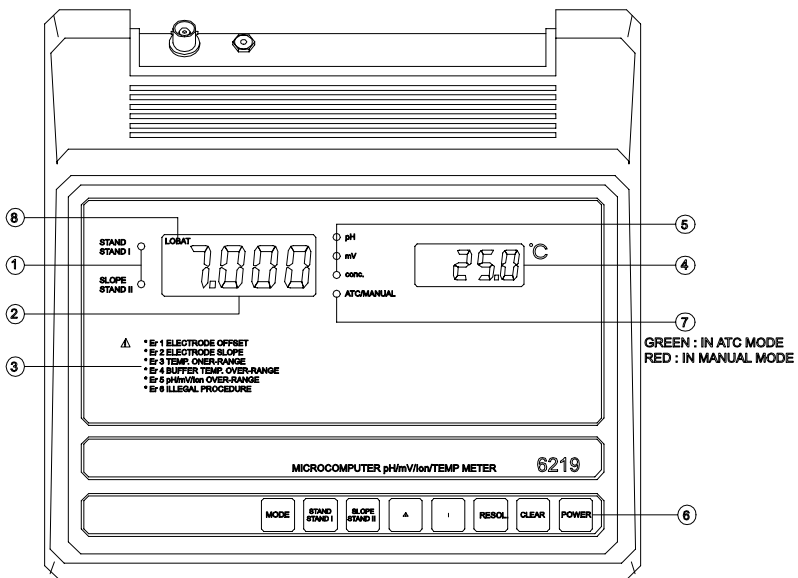
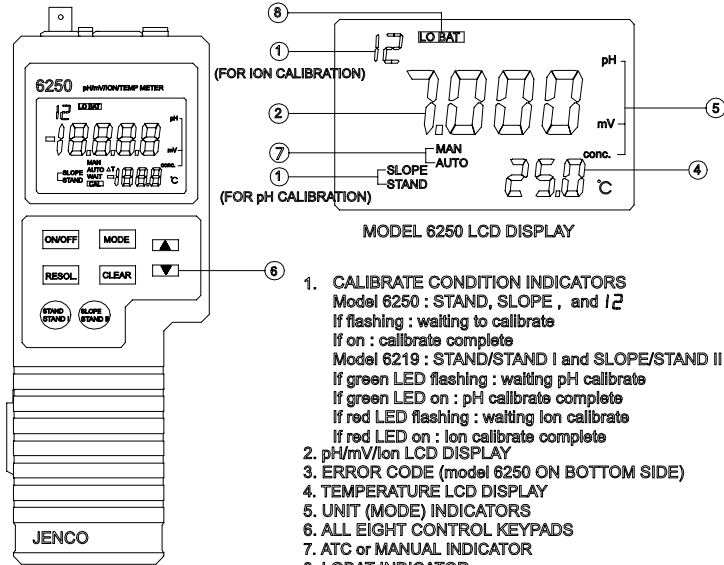

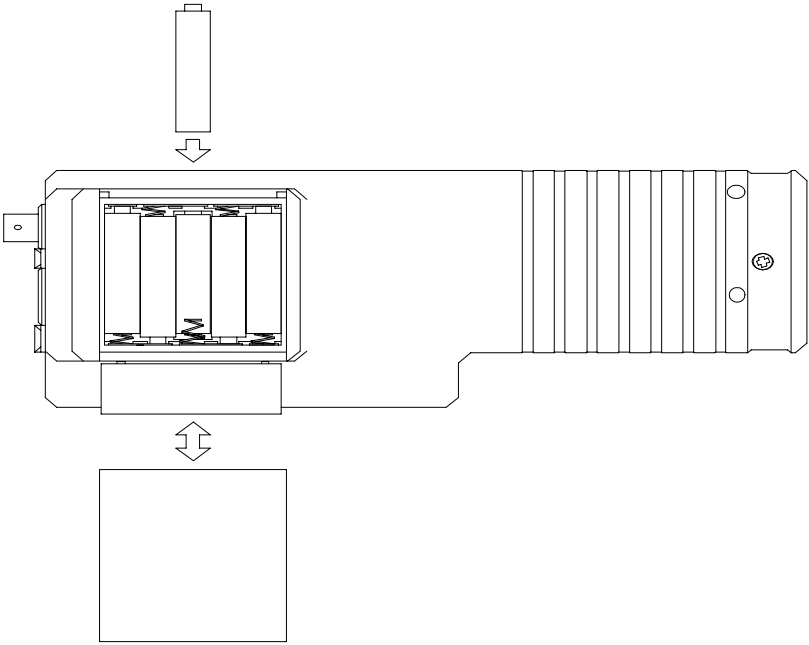

Figure 4

## SPECIFICATIONS

Model	6250	6219
Range	-2.000 to 16.000 pH	
pH Accuracy	+/-0.1% +/- 1 digit	
Resolution	0.01 pH or 0.001 pH (selectable)	
Range	-1999.9 to 1999.9 mV	
mV Accuracy	+/-0.1% +/- 1digit	
Resolution	1 mV or 0.1 mV (selectable)	
Range	-5.0 to 125.0 °C	
TEMP Accuracy	+/-0.5 °C	
Resolution	0.1 °C	
Range	0.00 to 119.8 conc.	
ION Accuracy	+/- 2 LSD	
Resolution	0.05 conc. (range 0.00 to 25.00 conc.) 0.1 conc. (range 25.00 to 50.0 conc.) 0.2 conc. (range 50.0 to 119.8 conc.)	
Operating temperature	0 to 50 °C	
Power supply	Six AAA batteries	Six AA batteries
9V AC adaptor	9V AC adaptor	
Display	pH/mV/ion	15mm high LCD
	TEMP.	12.7mm high LCD
Battery life	25 Hours	50 HOurs
Dimensions (W/D/H)	83mm/241mm/72mm 250mm/240mm/100mm	
WEight (w/batteries)	450gm	1070gm

### Touch Keys for Model 6219 and Model 6250

1. ON/OFF (POWER) key: The ON/OFF (POWER) key toggles the power of the instrument on and off. The current mode and pH/ion calibration values are saved to the internal non-volatile memory of the instrument when turned off and restored when turned back on.
2. MODE key: The MODE key selects the display mode of the instrument. Pressing the MODE key cycles the display sequentially from pH, mV and ion. The calibration values are not affected by changing the display modes.
3. STAND/STAND I, SLOPE/STAND II key: The STAND/STAND I and SLOPE/STAND II keys are for standardizing the instrument only.
4. UP and DOWN key: These keys are used to manually enter the temperature values. The UP key increments the temperature, while the DOWN key decrements the temperature. These keys will not respond when operating in the automatic temperature compensation (ATC) mode.
5. RESOL. key: The RESOL. key toggles the resolution of the instrument in pH or mV mode. But not for ion mode.
6. CLEAR key: The CLEAR key is used to reset the instruments mode and clear the pH/ion calibration values. The CLEAR key has a delayed reaction of 2 seconds before responding to protect from accidental key presses. However, When the instrument display an error the CLEAR key is pressed, all the LCD segments and annunciators will be on for a 2~3 seconds and the instrument will enter into the pH mode. The CLEAR key is intended to be used only when errors are made that require the instrument to be recalibrated.

## **MEASUREMENT ERROR INDICATIONS**

- Er1 1. pH electrode offset greater than +/- 1.5 pH range  
2. Buffer 7.00pH (model 6250/6219), 6.86pH (model 6250C/6219C) not correct
- Er2 1. pH electrode slope off by more than +/- 30 % of ideal slope  
2. Buffer 4.00pH, 9.18pH (model 6250C/6219C), 10.01pH (model 6250/6219) not correct
- Er3 Temperature out of the -5.0 to 125.0 degree C range
- Er4 Buffer temperature out of the 0 to 50.0 degree C range
- Er5 1. pH values out of the -2.000 to 16.000 pH range when in pH mode  
2. mV values out of the -1999.9 to 1999.9 mV range when in mV

mode

3. Ion values out of the 0 to 119.8 conc. range when in ion mode

## **OPERATIONAL PROCEDURES**

### **pH CALIBRATION**

Connect the AC adaptor to the AC power line. Make sure the correct AC adaptor is used. It is recommended to conserve the internal batteries by using AC power whenever it is available. Turn on the instrument by pressing the ON/OFF (model 6250)/ POWER (model 6219) key. The instrument will enter into the state when the instrument was last turned off. It is not necessary to press the CLEAR key. You also can press RESOL. key to select the optimum resolution you need.

1. Calibration with ATC/Temp probe in the pH mode.

A triaxle 3-in-1 pH/Ref/Temp electrode with user's electrode cable, can be used in place of a combination pH electrode and a separate ATC/Temp probe.

1.1 Connect the pH electrode and the ATC/Temp to the connectors of the instrument. Refer to the Figure 2. The ATC annunciator (model 6250)/ green color ATC LED lamp (model 6219) will be on. Press the MODE key to enter into pH mode, the pH annunciator (model 6250) or pH LED lamp (model 6219) will on and the STAND annunciator (model 6250) or green color STAND LED (model 6219) will flash.

1.2 Rinse the pH electrode and ATC/Temp probe in distilled water and immerse in pH 7.00 (model 6250/6219) or pH 6.86 (model 6250C/6219C). The instrument will display the buffer temperature.

1.3 Allow sufficient time for the electrode and ATC/Temp probe to stabilize. Press the STAND/STAND I key. The STAND indication will be on and the SLOPE annunciator (model 6250) or SLOPE green color LED lamp (model 6219) will flash, indicating that standardization at buffer 7.00pH or 6.86pH is complete and the instrument is ready to be sloped at a second buffer. The instrument will display the buffer value

corresponding to the temperature of the buffer 7.00pH or 6.86pH as measured in 1.2.

Refer to Table 1. If the reading still drifts, repeat 1.3 until a stable reading is obtained.

If Er1 is displayed, check to make sure that the correct buffer is used and that the electrode offset is less than  $\pm 1.5$ pH. Replace the buffer and/or the pH electrode. Press the CLEAR key and repeat from 1.2. Er1 may appear if the STAND/STAND I key is pressed before the electrode and ATC/Temp probe settle to within  $\pm 1.5$ pH of the buffer value. Allow sufficient time for the electrode and ATC/Temp probe to stabilize before taking any action.

If Er4 is display, The buffer temperature is out of the 0 to 50.0 degree C range. Bring the buffer temperature within range and repeat 1.2. It is not necessary to press the CLEAR key.

1.4 Remove the pH electrode and ATC/Temp probe from buffer 7.00pH or buffer 6.86pH, rinse with distilled water and immerse in buffer 4.01pH, 10.01pH (model 6250/model 6219) or buffer 4.00pH, 9.18pH (model 6250C/ model 6219C). The instrument will display the temperature of the second buffer.

1.5 Allow sufficient time for the pH electrode and ATC/Temp probe to stabilize. Press the SLOPE/STAND II key. The SLOPE indication will stop flashing and stay on. The instrument will display the second buffer value corresponding to the temperature of the second buffer as measured in 1.4. Refer to Table 1. If reading still drifts, repeat 1.5 until a stable reading is obtained. The micro computer inside the instrument will calculate and compensate for the pH electrode slope deviation corresponding to the values of the two calibration buffers. The instrument is dual point calibrated and is ready for measurements.

If Er2 is display, check to make sure that the correct buffer is used and that the slope of the electrode is not off by more than  $\pm 30\%$  from the theoretical slope. Replace the buffer and/or the pH electrode. Press

CLEAR key and repeat from 2.2. Only buffer 4.01 and 10.01 (model 6250/ model 6219 only) or Buffer 4.00 and 9.18 (model 6250C/ model 6219C only) may be used to slope the instrument. Er2 may appear if the SLOPE key is

pressed before the electrode and ATC/Temp probe settle to within +/- 30% of the buffer value. Allow sufficient time for the electrode and ATC/Temp probe to stabilize before taking any action.

If ER4 is displayed, the buffer temperature is out of the 0 to 50.0 degree C range. Bring the buffer temperature within range and repeat 1.2. It is not necessary to press the CLEAR key.

## **2. Calibration with manual temperature compensation in the pH mode**

2.1 Connect the pH electrode to the instrument. Refer to Figure 2. The MANUAL indication MAN (model 6250) or red color MANUAL LED lamp will be on. (Per Figure 3) Press the MODE key for the instrument enter into pH mode, the pH indicator will on and the STAND annunciator (model 6250) or green color STAND LED lamp (Model 6219) will start flash (Per Figure 3).

2.2 Rinse the pH electrode in distilled water and immerse in buffer 7.00 (model 6250/ model 6219) or 6.86. (model 6250C/ model 6219C) Set the instrument to display the temperature of the buffer 7.00 or 6.86 by pressing the UP or DOWN key.

2.3 Pressing the UP key will increase the temperature and the DOWN key will decrease the temperature. The displayed temperature must be within 0.0 to 50.0 degree C range.

2.4 Allow sufficient time for the electrode to stabilize. Press STAND/STAND I key. The STAND indication will be on and the SLOPE annunciator (model 6250) or green color SLOPE LED lamp (model 6219) will flash, indicating that standardization at buffer 7.00 or 6.86 is complete and the instrument is ready to be sloped at a second buffer. The instrument will display the buffer value corresponding to the temperature of the buffer 7.00 or 6.86 set in 2.2, 2.3. Refer to Table 1. If the reading still drifts, repeat 2.4 until a stable reading is obtained.

If Er1 is display, check to make sure that the correct buffer is used and

that the electrode offset is less +/- 1.5 pH. Replace the buffer and/or the electrode. Press CLEAR key and repeat from 2.2. Er1 may appear if the STAND/STAND I key is pressed before the electrode settles to within

+/- 1.5 pH of the buffer value. Allow sufficient time for the electrode to stabilize before taking any action.

- 2.5 Remove the pH electrode from buffer 7.00(model 6250/ model 6219) or 6.86(model 6250C/ 6219C), rinse with distilled water and immerse in buffer 4.01 or 10.01 (model 6250/ model 6219) or 4.00 or 9.18 (model 6250C/ model 6219C). Set the instrument to display the temperature of the second buffer, as in 2.3. The displayed temperature must be within 0 to 50.0 degree C range.
- 2.6 Allow sufficient time for the pH electrode to stabilize. Press the SLOPE/STAND II key. The SLOPE indication will stop flashing and stay on. The instrument will display the second buffer value corresponding to the temperature of the second buffer as set in 2.5. Refer to Table 1. If the reading still drifts, repeat 2.6 until a stable reading is obtained. The micro computer inside the instrument will calculate and compensate for the pH electrode slope deviation corresponding to the values of the two calibration buffer. The instrument is dual point calibrated and is ready for measurements.

If Er2 is displayed, check to make sure that the correct buffer is used and that the slope of the electrode is not off by more than +/- 30% from the theoretical slope. Replace the buffer and/or the pH electrode. Press CLEAR key and repeat from 2.2. Only buffer 4.01 and 10.01 (model 6250/ model 6219) or buffer 4.00 and 9.18 (model 6250C/ model 6219C) may be used to slope the instrument. Er2 may appear if the SLOPE/STAND II key is pressed before the electrode settles to within +/- 30% of the buffer value. Allow sufficient time for the electrode to stabilize before taking any action.

## **pH MEASUREMENTS**

The STAND and SLOPE indications must be on, indicating that the instrument is dual point calibrated and ready for measurements.

## **1. Measurement with ATC/Temp probe in the pH mode.**

- 1.1 Removed the pH electrode and rinse with distilled water and immerse it in the sample to be measured and the ATC annunciator (model 6250) or green color LED lamp (model 6219) will be on (Per Figure 3). The pH unit , ATC, STAND and SLOPE indicators are on .
- 1.2 The display will track the pH value as sensed by the pH electrode and the ATC/Temp probe. Allow sufficient time for the display to stabilize. The instrument will display the pH value of the sample at the displayed sample temperature.

If Er5 is displayed, the pH value measured is out of the -2.000 to 16.000 pH range.

## **2. Measurement with manual temperature compensation in the pH mode**

- 2.1 Connect the pH electrode to the connector of the instrument. Refer to Figure 2.
- 2.2 Press the MODE key enter into pH mode, the pH , STAND, SLOPE indicators is on and the MANUAL annunciator (model 6250) or red color LED lamp (model 6219) are on . (Per Figure 3)
- 2.3 Rinse the pH electrode with distilled water and immerse it in the sample to be measured.
- 2.4 Use the UP and DOWN keys to set the sample solution's temperature.
- 2.5 Allow sufficient time for the display to stabilize. The instrument will display the pH value of the sample at the set sample temperature.

If Er5 is displayed, the pH value measured is out of the -2.000 to 16.000 pH range.

## **TEMPERATURE MEASUREMENTS**

The two model 6250/6219 can be used to measure temperature independently with ATC/Temp probe with using the pH electrode.

- 1.1 If the pH electrode is not connected to the instrument, the pH input must shorted to the reference input by the protect cap.
- 1.2 Connect the ATC/Temp probe to the input connector. Refer to Figure 2. The ATC/MANUAL LED lamp will change from red color to green color and enter into ATC mode.
- 1.3 Place the temperature sensor in the media to be measured. The measured temperature is displayed.

Er3 will be displayed if the temperature is out of the temperature measurement range -5.0 to 125.0 degree C. Once the temperature brought within range, Er3 will disappear and the correct temperature reading will be displayed. It is not necessary to press the CLEAR key.

Er4 will be displayed if the temperature is out of the temperature range 0 to 50.0 degree C, Please press MODE key to enter into mV or Ion mode for the other measurements.

## **mV MEASUREMENTS**

A combination electrode can be used in place of the working electrode and the reference electrode. The MANUAL indication will be on if the ATC/Temp probe is not connected to the instrument.

- 1.1 Connect the working electrode to the input BNC connector and the reference electrode to the input Pin connector. Refer figure 2.
- 1.2 Press the MODE key for the instrument to enter into mV mode and press RESOL. key to select optimum resolution.

- 1.3 Rinse the working and reference electrode with distilled water and immerse the two electrode in sample to be measured.
- 1.4 Allow sufficient time for the display to stabilize. The instrument will display the millivolt value of the sample.

If Er5 is displayed, the millivolt value measured is out of the +/-1999.9 mV range. The instrument will display the correct value once the input millivolt is brought within range. It is not necessary to CLEAR the instrument.

- 1.5 The ATC/Temp probe can be used to measure the sample temperature as required.

## **ION MEASUREMENTS**

The following rules should be observed in order to make accurate determinations of ion concentration.

- Rule A. All hardwares used to handle ion standards and samples should always be cleaned with deioned water.
- Rule B. THE standard solutions and samples should always be at the same temperature.
- Rule C. A magnetic stirrer should be used for all measurements of standards and samples.
- Rule D. Study the instruction manual of the ION sensor carefully to make sure that the proper ionic strength adjuster and/or pH adjuster is used.

1.1 Connect the ION sensing electrode to the BNC connector and the reference electrode to the REF pin connector.

1.2 Prepare 2 standards 1 decade apart. The concentration of the sample should be within the range of the 2 standards. The 2 standards can be of any concentration unit such as ppm, mg/l or M.

1.3 Rinse the electrode with the dilute standard or de-ionized water and immerse the electrodes in the dilute stanard 1.

1.4 Press Mode key to enter into ION mode. The LCD display

will display ION , annunciator 1 ( on the higher left corner / model 6250) or red color STAND I LED (model 6219) lamp will flash and the conc. unit indicator will on. 1.5 Press the STAND/STAND I key, the LCD will display 1.00, annunciator 1 (on the higher left corner / model 6250) or STAND I LED lamp (model 6219) will on and annunciator 2 (on the higher left corner/ model 6250) or red color STAND II LED (model 6219) lamp will flash. The instrument is single point standardized and assumes a slope of +58 mV per decade change in concentration.

Er5 will be displayed if the input value exceeds +/- 750mV (approximately) or the display exceeds 120.0 conc.

Er2 will be display if the STAND II key is pressed before the STAND I key.

1.6 For dual point standardization, remove the electrodes from the dilute standard, rinse with the concentrate standard or de-ionized water and immerse the electrodes in the concentrate standard 2.

1.7 Press the STAND II key, the annunciator 2 (model 6250) or STAND II LED (model 6219) lamp will on. The STAND II key can be pressed as many times as required for a stable reading of 10.00 conc. The instrument is dual point standardized and ready for measurements. The electrodes should always be rinsed with the sample or de-ionized water before measurements.

Er2 will be displayed if electrode slope small than 50% of ideal slope, 58 mV.

Er5 will be displayed if the input value exceeds +/- 750 mV (approximately) or the display exceeds 120.0 conc.

## TEMPERATURE COEFFICIENT OF pH BUFFERS

### BUFFERS

TEMP(C)	4.01	6.86	7.00	9.18	10.01
0	4.003	6.982	7.119	9.460	10.321
5	3.998	6.949	7.086	9.392	10.248
10	3.996	6.921	7.058	9.331	10.181
15	3.996	6.898	7.035	9.276	10.120
20	3.999	6.878	7.015	9.183	10.064
25	4.004	6.683	7.000	9.183	10.014
30	4.011	6.851	6.988	9.143	9.968
35	4.020	6.842	6.979	9.107	9.928
40	4.030	6.836	6.973	9.074	9.891
45	4.042	6.832	6.969	9.044	9.859
50	4.055	6.831	6.968	9.017	9.831

The actual reading of the instrument can differ from the values shown by +/- 1 digit.

TABLE 1

The value in TABLE 1 is stored in the memory of the microcomputer. Since the buffer values stored is the value of the buffers at 0, 5, 10, 15, 20, 25, 30, 35, 40, 45 and 50 degree C. It is recommended to keep the buffers at above temperatures or close to room temperature to minimize the error of the buffer.

# **Operating the Meter Using the RS232C Interface**

## **INTRODUCTION**

This section assumes you are familiar with the basic of data communication, the RS232C interface, rudimentary knowledge and a copy of any of the following computer languages: Turbo Basic, Quick Basic, Turbo PASCAL and Turbo C.

This meter can only be operated using the RS232C interface by using the software driver included with this meter and writing a simple program to send and receive data from the meter using any of the above mentioned computer languages.

An annotated sample programs for each computer language and amore detailed explanation of the software driver are included in the accompanying disk.

## **PREPARING THE METER FOR OPERATIONS VIA THE RS-232C INTERFACE**

The Meter comes equipped with an RS232C (serial) interface. The meter communicates with a PC computer (100% IBM PC/AT compatibles) through a DB-9 interface connector (model 6250) or DB-25 interface connector (model 6219). using a standard RS232 cable for interconnecting two IBM PC/ATs can be use.

Connecting the cable and turning on the meter and the computer, you are now ready for the software part of the operation.

## **SOFTWARE PREPARATION**

The accompanying disk includes a special software driver to let you easily write a simple program to read data from the meter. By

incorporating the driver to your software you can then use the special

commands without worrying about the protocol between the meter and your computer.

For the model 6250 Reading "MAN6250.TXT" in the accompanying disk will jumpstart you to using the meter with its RS232C interface. "MANUAL.TXT" is the general explanations of the various serial commands available in the driver.

For the model 6219 Reading "MAN6219.TXT" in the accompanying disk will jumpstart you to using the meter with its RC232C interface. "MANUAL.TXT" is the general explanations of the various serial commands available in the driver.

## **MODEL 6250/ MODEL 6219 RS232 PARAMETERS**

BAUD RATE : 2400 (FIXED)  
PARITY : SOFTWARE DRIVER CONTROLLED  
DATA BITS : 8  
STOP BIT : 1  
PROTOCOL : SOFTWARE DRIVER CONTROLLED.

## **WARRANTY**

Jenco Instruments, Ltd. Warrants this product to be free from significant deviations in material and workmanship for a period of 1 year from date of purchase. If repair or adjustment is necessary and has not been the result of abuse or misuse, within the year period, please return-freight-prepaid and the correction of the defect will be made without charge. If you purchased the item from our Jenco distributors and it is under warranty, please contact them to notify us of the situation. Jenco Service Department alone will determine if the product problem is due to deviations or customer misuse.

Out-of-warranty products will be repaired on a charge basis.

## **RETURN OF ITEMS**

Authorization must be obtained from one of our representatives before returning items for any reason. When applying for authorization, please have the model and serial number handy, including data regarding the reason for return. For your protection, items must be carefully packed to prevent damage in shipment and insured against possible damage or loss. Jenco will not be responsible for damage resulting from careless or insufficient packing. A fee will be charged on all unauthorized returns.

**NOTE:** Jenco Instruments, Inc reserves the right to make improvements in design, construction, and appearance of our products without notice.

### **JENCO INSTRUMENTS, INC.**

7968 Arjons Drive, Suite C  
San Diego, CA 92126 USA  
TEL:001-858-5782828 FAX:001- 858-5782886  
E-MAIL: [jencoi@ix.netcom.com](mailto:jencoi@ix.netcom.com)  
Homepage:<http://www.jencoi.com>

### **JENCO ELECTRONICS, LTD.**

PO. BOX LINKOU 117  
TAIPEI, TAIWAN  
TEL: (886-2)2601-6191 FAX: (886-2)2601-7206  
E-MAIL: [jencoe@ms2.hinet.net](mailto:jencoe@ms2.hinet.net)

### **SHANGHAI JENCO ELECTRONICS, LTD.**

18 Wang Dong Zhong Road  
Sijing Town, Songjiang  
SHANGHAI, CHINA  
TEL: (86-021)5761-9599 FAX: (86-021)5761-9598  
E-MAIL: [jenco@public.sta.net.cn](mailto:jenco@public.sta.net.cn)  
Homepage:<http://www.jenco.com.cn>