

# **OPERATION MANUAL**

---

---

## **JENCO MODEL 6308DT MICROCOMPUTER BASED DO/ Temperature CONTROLLER**

**JENCO** ELECTRONICS, LTD.  
MANUFACTURER OF PRECISION INSTRUMENTS

# I. GENERAL INTRODUCTION

The Jenco Model **6308 DT** (DO and Temperature) System, is a rugged microprocessor based instrument assembled in a watertight  $\frac{1}{4}$  DIN case, designed for use in laboratories and process control applications.

The model 6308 DT microprocessor allows the user to easily recalibrate the parameters for the probes. The DO system requires only a single calibration, regardless of which dissolved oxygen display you use. The microprocessor also performs a self-diagnostic routine every time you turn on the unit providing you with basic information about the stability of the instrument.

The system simultaneously displays DO, Temperature, Relay status and current output in one LCD graphic screen. The LCD also includes a backlight for badly lit environments. This system uses a "polygraphic clark" membrane for the DO and a precise thermistor for temperature, providing you with accurate readings for all your measurements.

The model 6308 DT is equipped with 5 relays (2 active Low and 2 active High relays for DO and one programmable high or low relay for temperature); all relays are hysteresis driven and configurable to **CENTER** or **EDGE** mode. The system also has a **isolated 4-20mA** analog output, offset and span configurable for the DO display.

The model 6308 DT comes with a RS485 interface which can easily let the user log all data (from multiple model 6308 or 6309) with an IBM® PC/AT compatible computer.

## II. INITIAL INSPECTION

Carefully unpack the instrument and accessories. Inspect for damages made in shipment. If any damage is found, notify your Jenco representative immediately. All packing materials should be saved until satisfactory operation is confirmed.

### MOUNTING PROCEDURE

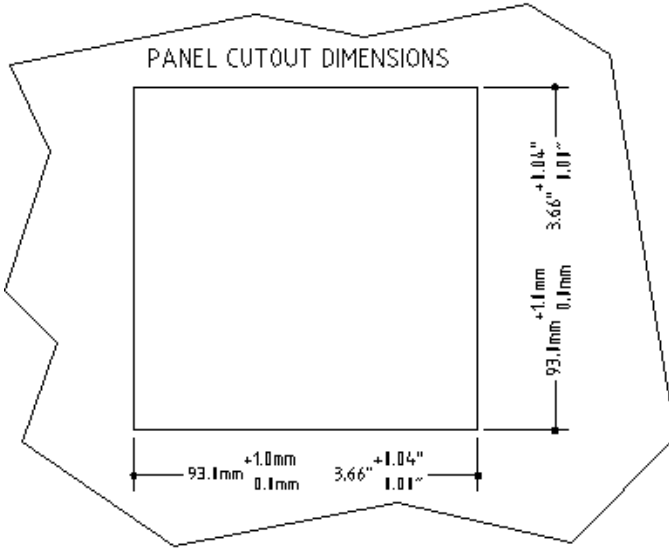

1. Make a cutout on any panel, with a thickness of 1/16 in. (1.5 mm) to 3/8 in. (9.5mm).
2. Remove the mounting assembly from the controller and insert the controller into the cutout.
3. Replace the mounting bracket assembly onto

the controller and secure the controller to the mounting panel.

### Warning :

If the equipment is used in a manner not specified by the manufacturer, the protection provided by the equipment may be impaired.

### Cleaning the instrument :

1. Be sure to remove the power before attempting to clean the meter.
2. Use a lint free cloth and clean water or neutral detergent.
3. Wipe the outer surface of the instrument only.
4. Wipe dry the instrument before power again.

## III. USING THE JENCO MODEL 6308 DT

## A. FRONT PANEL

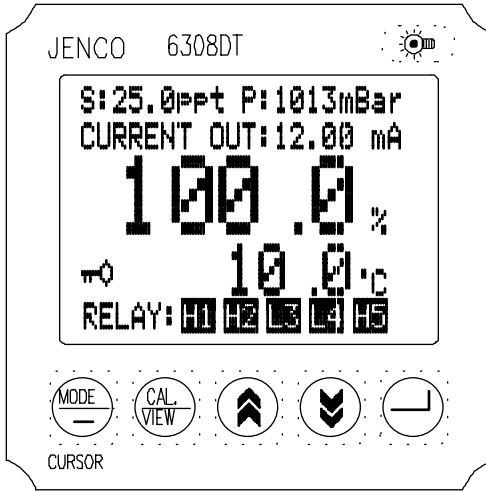

1. The [ **MODE/-** ] key.
  - 1a. In **Normal** mode this key will change the DO display to DO % or DO ppm.
  - 1b. In **Calibration/ Setting** mode this key will move to the next digit of the current active parameter.
  - 1c. In **Calibration/ Setting** mode, pressing this key for 2 seconds will move you back to the previous parameter.

2. The [ **CAL/VIEW** ] key.

2a. In Normal mode, the display will go to **Calibration / Setting** mode if you press this key for about 2 seconds

2b. During **Calibration/Setting** mode this key will switch to the next available **Calibration/Setting** page. Pressing this key at the last **Calibration / Setting** page will return the user to the Normal mode.

3. The [ **▲** ] **UP** key.

During **Calibration/Setting** mode this key will **increment** the current blinking digit of the active parameter.

4. The [ **▼** ] **DOWN** key.

During **Calibration/Setting mode** this key will **decrement** the blinking digit of the active parameter

5. The [ **↵** ] **ENTER** key.

During **Calibration/Setting** mode this key will save the current modified parameter and move to the next parameter on the page if the parameter is the last one in the page then it will move to first parameter on the next available page.

6. The [  ] **LIGHT** key.

This key will turn on or turn off the backlight of the LCD.

The backlight will automatically turn off if there is no key activity for about two minutes.

7. LCD screen.

**B. NORMAL MODE DISPLAY**

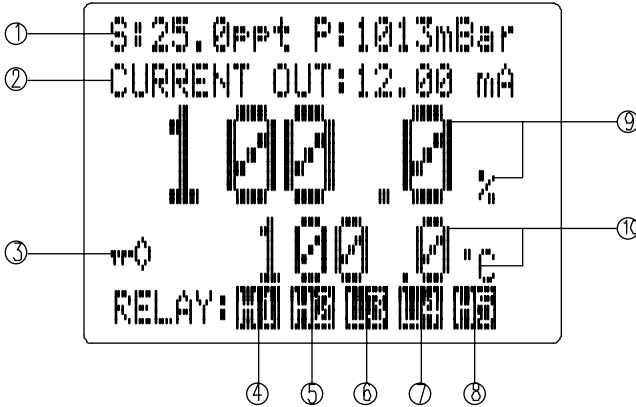

1. **S:**, **P:** - Salinity and Pressure settings.
2. **CURRENT OUT** - this will display the actual reading of the 4-20 mA output. At POWER-ON this will show "OFF" for about 3 seconds before going to main display mode. After exiting the Calibration /Setting pages, a "FROZEN" message will be displayed for about 3 seconds if the unit is not password locked.
3.  annunciator - This will be displayed if Calibration/Setting pages are password locked meaning the user can't change the values unless the correct 4 digit number has been entered.
4. **H1** annunciator - this is the status of DO Relay 1, if this is displayed then the relay is ON.
5. **H2** annunciator - this is the status of DO Relay 2, if this is displayed then the relay is ON.
6. **L3** annunciator - this is the status of DO Relay 3, if this is displayed the Relay is ON.
7. **L4** annunciator - this is the status of DO Relay 4, if this is displayed then the Relay is ON.
8. **H5** or **L5** annunciator - this is the status of the Temperature

Relay 5, if this is displayed then the Relay is ON. **H5** means the relay action is HIGH while **L5** means the relay action LOW.

9. Dissolved oxygen (% or ppm) display.

10. Temperature display.

### C. REAR CONNECTORS

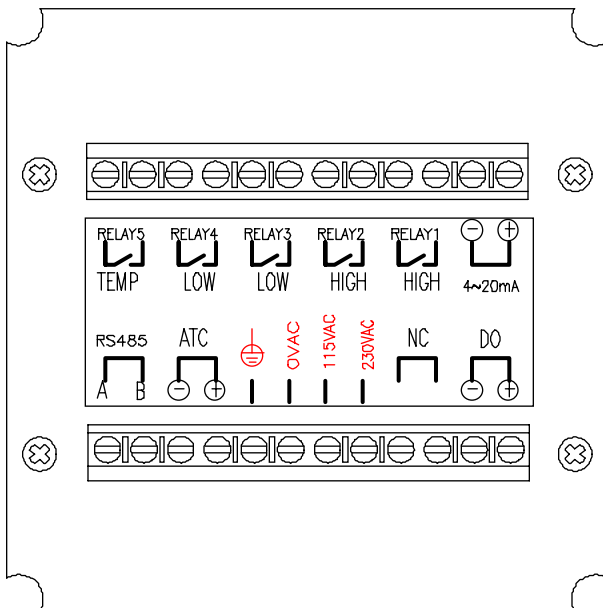

Before wiring the probes, relays, analog output, RS485 and power cord be sure that you are connecting to the right terminal as shown above. Remember that the unit is ON once the user plugs in the power cord to an AC power supply.

1. Connect the AC line to the rear of the instrument. The model 6308PT can be used with 115VAC or 230VAC 50/60 Hz. Power consumption is 6 watt. Make sure the **EARTH** connector is connected to the earth lead of the AC power line.
2. Connect the proper load to the output relays. **Make sure that the load does not exceed the relay rating, 5 Amp at 115VAC and 2.5 Amp at 230 VAC.**

3. Set the proper load to the 4-20mA output connector. Make sure that the load impedance is less than 500 Ohms.

## CAUTION:

MAKE SURE YOU CONNECT THE AC POWER CORD TO THE CORRECT AC TERMINALS. CONNECTING INCORRECTLY MAY DAMAGE THE UNIT PERMANENTLY.

## D. TURNING ON/OFF THE INSTRUMENT

By just plugging the unit to a correct AC voltage the unit will be ready for use. There is **no Power key** so unplugging and plugging the unit will turn OFF or turn ON the unit respectively.

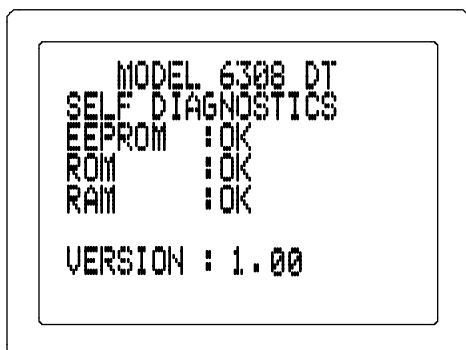

After the unit is turned on, it will perform some basic self-diagnostics and will display "OK" or "BAD". If you received any "BAD" messages turn OFF the unit and turn it ON again. (See **VIII. ERROR DISPLAYS AND TROUBLESHOOTING**).

If the message persists then you might need to call your distributor. (See **X. WARRANTY**).

After the self-diagnostic is complete the temperature will be displayed on the lower part of the LCD screen and you are ready to make DO calibration or measurements. Just immerse the probes halfway to the liquid. If possible do not allow the probes to touch any solid object in the solution. There should be no air bubbles around the probes either. Shaking or moving the probes vigorously before recording any measurement will dislodge any bubbles formed in the probes.

## IV. MODEL 6308 DT MODES

### A. MAIN DISPLAY MODE

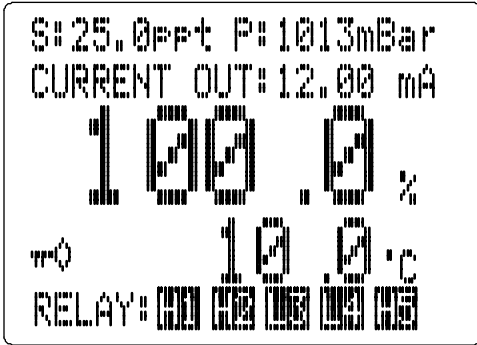

Turning ON the unit will always start in main display mode.

This instrument is designed to provide 3 distinct measurements :

1. Temperature - current temperature of the solution which is always displayed
2. Dissolved Oxygen % - a measurement of oxygen in percent saturation.
3. Dissolved Oxygen ppm - a measurement of oxygen in ppm.

Temperature and DO (% or ppm) are always simultaneously displayed in the graphic LCD screen in normal mode. You can select which DO unit to display by pressing the [MODE/-] key.

### B. CALIBRATION/SETTING MODE

Pressing the [CAL/VIEW] key for about 2 seconds during main display mode will bring-up the first page of 6 pages of the **Calibration/Setting** mode. Pressing [CAL/VIEW] key will switch to the next page until the last page, where pressing [CAL/VIEW] again will return the user to main display mode.

Below is a simple flowchart showing the path of the [CAL/VIEW] key:

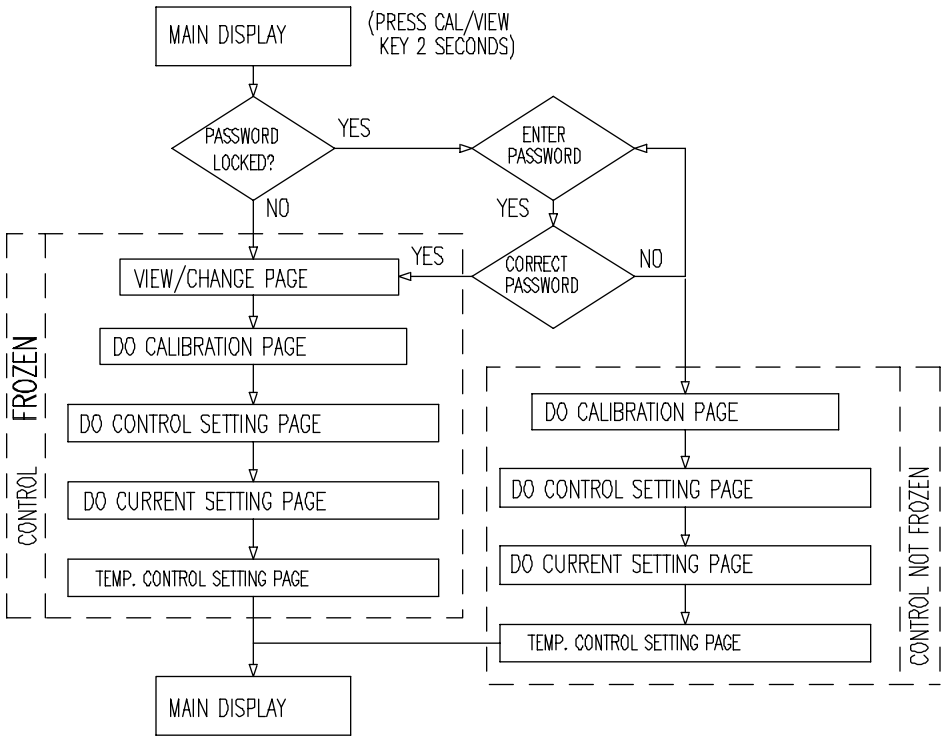

You can change any blinking options or digit by pressing the [ ▲ ] or [ ▼ ] keys. For options in digit format you need to press the [ **MODE/--** ] key to move to the next digit . If you are satisfied with the selection you made you need to press the [ ↵ ] **ENTER** key to save the changes and move to the next option. If you don't need to change the current blinking option just press the [ ↵ ] **ENTER** key to move to the next selection.

a. **CHECK PASSWORD** page



You will only see this page if the unit is password locked. To change any settings or calibration you need to unlock the system to remove the "PASSWORD LOCKED"

message. You need to enter the correct 4-digit number on the "ENTER PASSWORD" input. You can still view all the pages of **Calibration/Setting mode** if the system is password locked by just pressing the [CAL/VIEW] key on this page. If the unit is "PASSWORD LOCKED" going to **Calibration/Setting mode** will not affect the function of the relays.

**CAUTION: If the unit is not locked then every time the user enters the Calibration/Setting mode the relays and analog out will be frozen.**

```

USER SETTING

!! WARNING !!
RELAYS & ANALOG OUT
ARE NOW FROZEN!

PRESS [CAL/VIEW] TO PROCEED
    
```

b. **USER SETTING** page - You will only see this page if the unit is not password locked. This page is just a warning, telling you that all relays are frozen, and that you can calibrate and change the settings.

**NOTE: FROZEN MEANS ALL THE RELAYS AND THE**

**ANALOG OUT WILL MAINT IN THEIR LAST STATE UNTIL THE USER RETURNS TO MAIN DISPLAY MODE.**

### c. DO CALIBRATION

```

DO CALIBRATION
ATC TEMP. : 25.0°C
1. PRESSURE : 1013mBar
2. SALINITY : 0.0 PPT
3. RELAY/MA UNIT: %
4. CAL VALUE: 100.0 %
* SAVING *
    
```

**ATC TEMP.** - The current temperature of the solution.

1. **PRESSURE** - user changeable pressure value for DO computations.

2. **SALINITY** - user changeable salinity value for DO computations.

3. **DO ALARM UNIT** - this is the unit which the **DO RELAY1**

to **DO RELAY4** will be based upon. The RELAY1 to RELAY4 values for % and **ppm** unit are saved in different memory(eeprom) location.

4. **CAL VALUE** : this is the DO calibration option. If you move the cursor to this line a flashing [ ↵ ] icon will appear . Pressing the [ ↵ ] ENTER key will start the DO calibration. The unit of this calibration will depend on the unit of DO at normal mode. To accurately calibrate the model 6308 DT you will need the following information:

- i. The approximate pressure (in mbar) of the region in which you plan to take your dissolved oxygen measurements.
- ii. The approximate salinity of the water you will be analyzing. Fresh water has a salinity of approximately zero. Sea water has a salinity of approximately 35 parts per thousand (ppt).

## CALIBRATION PROCEDURES

- a. Place 5-6 drops of distilled water into the sponge inside the calibration bottle. Turn the bottle over and allow any excess water to drain out of the bottle. The wet sponge creates a 100% water saturated-air environment for the probe which is ideal for calibration, transport and storage of the Model 6308 DT probe.
- b. Screw in the bottle into probe allowing at least 5 mm space between the probe and the sponge.
- c. Wait around 30 minutes for the dissolved oxygen and temperature readings to stabilize. Pressing the [ ↵ ] ENTER key will start the calibration.
- d. If you are calibrating in % then the 100% calibration will be displayed. An error will be displayed if the input is not within the normal DO range. A [ ↵ ] icon will flash, pressing the [ ↵ ] ENTER key will start the calibration. If the input is not within the DO calibration limit then an error message will be displayed. If all is well then it will save the new calibration and move to the next page.

e. If you are calibrating in **ppm** then the current reading in ppm will be displayed. If you press the [↵] **ENTER** key, the unit will capture the current value and then you can change the value by using the [MODE/-] , [▲] UP and [▼] DOWN keys. If you are satisfied with the ppm value, you need to press the [↵] **ENTER** key to save the new calibration. If the DO input is within calibration range then the new calibration will be saved and move to the next page, otherwise an error message will be displayed.

#### d. DO CONTROL SETTING

```

DO CONTROL SETTING
1. HI RELAY 1: 140.0%
2. HI RELAY 2: 100.0%
3. LO RELAY 3: 40.0%
4. LO RELAY 4: 00.0%
5. HYSTERESIS: CENTER
6. HYSTERESIS: 10.0%
* SAVING *

```

**HI RELAY 1** - The action for this relay is fixed to HIGH. In HI-action the relay will turn ON if the DO is greater or equal to RELAY 1 value, which is modified by the hysteresis value and hysteresis mode. (See chapter V. CONTROLLING THE RELAYS ).

Use [▲] and [▼] keys to change the blinking digit, use the [MODE/-] key to select another digit and the [↵] key to save the new value.

2. **HI RELAY 2** - The action for this relay is fixed to HIGH. In HI-action the relay will turn ON if the DO is greater or equal to RELAY2 value, which is modified by the hysteresis value and hysteresis mode. (See chapter V. CONTROLLING THE RELAYS .) Use [▲] and [▼] keys to change the blinking digit, use the [MODE/-] key to select another digit and the [↵] key to save the new value.

3. **LO RELAY 3** - The action for this relay is fixed to LOW. In LO-action the relay will turn ON if the DO is less than or equal to RELAY3 value, which is modified by the hysteresis value and hysteresis mode. (See chapter V. CONTROLLING THE

**RELAYS** .) Use [▲] and [▼] keys to change the blinking digit, use the [MODE/--] key to select another digit and the [↵] key to save the new value.

4. **LO RELAY 4** - The action for this relay is fixed to LOW. In LO-action the relay will turn ON if the DO is less than or equal to RELAY4 value, which is modified by the hysteresis value and hysteresis mode. (See chapter V. **CONTROLLING THE RELAYS** .) Use [▲] and [▼] keys to change the blinking digit, use the [MODE/--] key to select another digit and the [↵] key to save the new value.

5. **HYSTERESIS (mode)** -this is the hysteresis mode for DO RELAY 1 to RELAY 4. You can choose "CENTER" or "EDGE". (See chapter V. **CONTROLLING THE RELAYS**.)

6. **HYSTERESIS (value)** - this is the actual value of the hysteresis. You can change this value from 1.0 to 99.9 % or 1.00 to 9.99 ppm . ( See chapter V. **CONTROLLING THE RELAYS** .)

#### e. CURRENT SETTING page

```
CURRENT SETTING
1. 4mA OUT:    00.0%
2. 20mA OUT:   100.0%

* SAVING *
```

1. **4mA OUT** - This value will be used in conjunction with 20 mA to plot the current output. (See chapter VI. **4-20 mA OUTPUT** .)

2. **20mA OUT** - This value will be used in conjunction with the 4 mA value to plot the output. (See chapter VI. **4-20 mA OUTPUT** .)

#### f. TEMP. CONTROL SETTING

```
TEMP. CONTROL SETTING
1. RELAY 5 : HIGH
2. SET POINT : 100.0 °C
3. HYSTERESIS : EDGE
4. HYSTERESIS : 1.0 °C
5. RS 485 ID : 00
6. PASSWORD SET: 0000
* SAVING *
```

1. **RELAY 5** - the temperature has only one relay to control you need to set what action it will use, HIGH or LOW action. . (In HIGH-action the relay will turn ON if the temperature is greater or equal to RELAY5 value, in LOW-

action the relay will turn **OFF** if the temperature is less than or equal to RELAY5 value, which is modified by the hysteresis value and hysteresis mode.)(See chapter V. **CONTROLLING THE RELAYS** .)

2. **SET POINT**- this is the user changeable value for the Temperature Alarm relay.

3. **HYSTERESIS (mode)** -this is the hysteresis mode for TEMPERATURE alarm. You can choose “**CENTER**” or “**EDGE**”. (See chapter V. **CONTROLLING THE RELAYS** .)

4. **HYSTERESIS (value)**- this is the actual value of the hysteresis. You can change this value from 0.0 to 19. 9°C. (See chapter V. **CONTROLLING THE RELAYS** .)

5. **RS 485 ID** - this is the unique ID/Address for the unit. If you are connecting multiple model 6308 DT or other Jenco models for logging purposes then this ID/Address must be unique for each connected unit. This ID/Address is the same address that must be used by the PC program to communicate with this unit.

6. **LOCK NO** - this is your security code if the unit is locked the value here will not be available. You need to input the correct code in the PASSWORD CHECK page.

**CAUTION:** The user is responsible in remembering their password number otherwise you would no be able to calibrate or change the settings.

## **V. CONTROLLING THE RELAYS**

### **A. ISOLATION VOLTAGE**

The maximum isolation voltage of the relay output contacts is 1500 VDC. The voltage differential between the relay output contacts and the load should not exceed 1500 VDC.

### **B. OUTPUT LOAD**

The current through the relay output contacts should not exceed **5 Amp at 115 VAC** and **2.5 Amp at 230 VAC** in order not to cause permanent damage to the relay contacts. This rating is specified for **resistive loads only**.

**C. RELAY ACTION, RELAY SETPOINT, HYSTERESIS MODE & HYSTERESIS VALUE**

Relay Action	Hysteresis mode	Effective RELAY-ON Setpoint	Effective RELAY-OFF Setpoint
HIGH	CENTER	S.P.+ ½(H.V.)	S.P. -½ (H.V.)
HIGH	EDGE	S.P.	S.P. -(H.V)
LOW	CENTER	S.P.-½ (H.V.)	S.P.+½ (H.V.)
LOW	EDGE	S.P	S.P.+(H.V.)

S.P. = Relay Set point

H.V.= Hysteresis value (DeadBand)

If the relay action is set to **HIGH** and the hysteresis mode is **CENTER**, the relay will turn **ON** at [(RELAY SETPOINT) + (0.5 \* hysteresis value)], and will turn **OFF** at [(RELAY SET POINT) - (0.5 \* hysteresis value)].

If the relay action is set to **HIGH** and the hysteresis mode is **EDGE**, the relay will turn **ON** at (RELAY SET POINT), and will turn **OFF** at [(RELAY SET POINT) - (hysteresis value)].

If the relay action is set to **LOW** and the hysteresis mode is **CENTER**, the relay will turn **OFF** at [(RELAY SET POINT ) + (0.5 \* hysteresis value)], and will turn **ON** at [(RELAY SET POINT) - (0.5 \* hysteresis value)].

If the relay action is set to **LOW** and the hysteresis mode is **EDGE**, the relay will turn **ON** at (RELAY SET POINT), and will turn **OFF** at [RELAY SET POINT+ (hysteresis value)].

## C. DO RELAYS

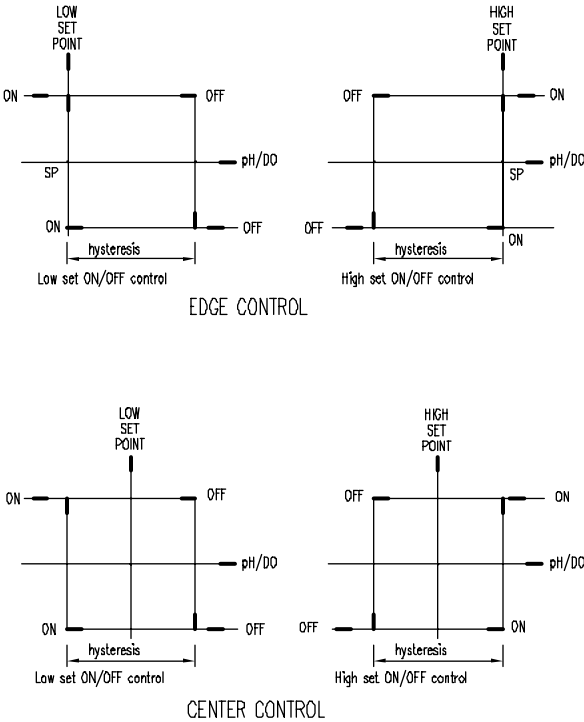

There are four independent Alarm channels for DO display. (see **figure 1**). The hysteresis mode (center or edge, see **figure 1**) and hysteresis value will be used by four DO relays.

The actions of the DO relays are dependent on set point, relay action type (HIGH or LOW), hysteresis mode (Center or Edge) , hysteresis value and the current DO display. (see **figure 1**).

**Figure 1**

D.

## TEMPERATURE RELAY

One relay channel is available for temperature display which has independent set point , action (see **figure 1**) setting ( HIGH or LOW ), hysteresis mode (center or edge) and hysteresis value.

The action of the Temperature relay is dependent on **set point**, **relay action type** (HIGH or LOW), **hysteresis mode** (Center or Edge) , **hysteresis value** and the **current Temperature display**. (See **figure 1**).

## VI. 4 - 20 mA OUTPUT

### A. ISOLATION VOLTAGE

The maximum isolation voltage of the 4-20 mA output is 500 VDC. The voltage differential between the 4-20 mA output and the load should not exceed 500 VDC.

## B. OUTPUT LOAD

The maximum load is 500Ω. Output current inaccuracies may occur for load impedance in excess 500Ω.

## C. DO LINEAR OUTPUT

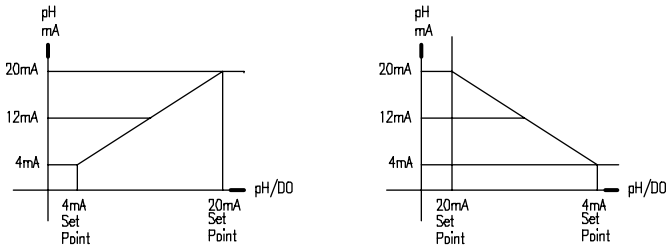

← DO LINEAR output .

**Fig. 2**

The analog output will produce a linear analog output if the user selects this option. The analog output will be dependent on the **DO\_4 mA setting**, **DO\_20 mA setting** and the **current DO display**. The DO LINEAR analog output is based on the following equation :

$$\text{mA}_{(\text{DO})} = 4\text{mA} + (16\text{mA}) * (\text{D}_{(\text{DO})} - \text{DO}(4)) / (\text{DO}(20) - \text{DO}(4))$$

Where :

- $\text{mA}_{(\text{DO})}$  = analog output
- $\text{D}_{(\text{DO})}$  = current DO display
- $\text{DO}(4)$  = DO user setting for 4 mA
- $\text{DO}(20)$  = DO user setting for 20 mA.

**Note :**

1. The range for 4mA and 20mA settings is 0.0 to 500.0% or 0.00 to 60.00 mg/L.
2. The absolute difference of the 4mA and 20 mA settings must be greater or equal to 1.0% or 0.10 mg/L or else the analog output will be disabled.

# VII. RS485 INTERFACE OPERATION

## A. INTRODUCTION

This section assumes you are familiar with the basics of data communication, the RS485 interface, a rudimentary knowledge and a copy of the more popular Windows® 9X computer languages capable of using a PC RS485 card or RS232-RS485 converter (third party vendor) module .

A simple program must be written in order to send your command and receive data from the meter.

A sample source program in Visual Basic® 6.0 is included in the accompanying disk.

## B. PREPARING THE METER

This meter comes equipped with a 2-wire RS485 interface. Just connect each terminal to the respective RS485 terminal on your PC. (If the DEMO program is not working, try reversing the connections of the terminals.) After you have connected correctly the meter (or multiple meters with unique ID number) and turned on both the meter(s) and the computer, you are now ready to program a simple routine to read data from the instrument.

Read the file "6308DT.TXT" in the accompanying disk to jump-start you in using the meter with your RS485 enabled PC.

# VIII. ERROR DISPLAYS AND TROUBLESHOOTING

LCD display	ATC display	DISPLAY unit	Possible cause(s) [Action(s)]
"UNDR"	a. >50.0 °C b. "OVER"	a. % or ppm -DO b. % or ppm -DO cal	a. Temperature > 50.0°C. [Bring solution to a lower temperature.]

"OVER"	"UNDR"	% or ppm-DO	Temperature < -10.0°C. [Bring buffer/solution to a higher temperature.]
<b>EEPROM: BAD</b>		During power-on	Unit has failed its EEPROM test. [Turn instrument OFF and back to ON again.] [Return for service. (see X.Warranty)]
<b>ROM : BAD</b>		During power-on	Unit has failed its ROM test. [Turn instrument OFF and back to ON again.] [Return for service. (see X.Warranty)]
<b>RAM : BAD</b>		During power-on	Unit has failed its RAM test. [Turn instrument OFF and back to ON again.] [Return for service. (see X.Warranty)]

## IX. SPECIFICATIONS

### DO

Display	Range	Accuracy	Resolution
Dissolved O <sub>2</sub> % air-sat	0 to 500.0%	±0.2 % of span (meter only)	0.1%
Dissolved O <sub>2</sub> % (ppm)	Depends on DO%	±0.2 % of span (meter only)	0.01ppm

### Temperature

Range	Resolution	Accuracy
-10.0 to 120.0 °C	0.1 °C	±0.1 °C

### DO

**Salinity compensation**

0.0 to 40.0 ppt (manual)

**Pressure compensation**

640 to 1100 mBar (manual)

**Temperature compensation**

-10.0 to 50.0 °C (automatic)

### Temperature

**Temperature sensor**

Thermistor, 2252Ω at 25°C

## **4-20mA Output**

<b>Current output range</b>	4 to 20 mA (isolated)
<b>Current output scale</b>	user programmable
<b>Maximum load</b>	500 $\Omega$
<b>Accuracy</b>	$\pm 0.02\text{mA}$
<b>Isolation voltage</b>	500VDC

## **Controller**

<b>Control type</b>	ON/OFF control
<b>Relay output</b>	5A at 115VAC or 2.5A at 220VAC

## **GENERAL**

<b>Keys</b>	Audio feedback in all keys
<b>Security protect</b>	4-digit password
<b>Communication</b>	RS485
<b>Power:</b>	115VAC or 230VAC 50/60Hz
<b>Ambient Temperature range</b>	0.0 to 50.0 $^{\circ}\text{C}$
<b>Display:</b>	128x64 graphic LCD w/ backlight
<b>Case</b>	IPT65 $\frac{1}{4}$ DIN case, depth 155mm
<b>Weight</b>	950 g

## **XII. WARRANTY**

Jenco Instruments, Ltd. Warrants this product to be free from defects in material and workmanship for a period of one year from date of purchase. If repair or adjustment is necessary and has not been the result of abuse or misuse, within the one year period, please return-freight-prepaid and the correction of the defect will be made without charge. If you purchased the item from our Jenco distributors and it is under warranty, please contact them to notify us of the situation. Jenco Service Department will determine whether the product problem is due to defects or customer misuse. Out-of-warranty products will be repaired on a fee basis.

## **RETURN OF ITEMS**

Authorization must be obtained from one of our representatives before returning items for any reason. When applying for authorization, please have the model and serial number handy, including all relevant information regarding the reasons for return. For your protection, items must be

Carefully packed to prevent damage in shipment and insured against possible damage or loss. Jenco will not be responsible for damage resulting from careless or insufficient packing. A fee will be charged on all unauthorized returns.

**NOTE:** Jenco Instruments, Inc reserves the right to make improvements in design, construction, and appearance of our products without notice.

**JENCO INSTRUMENTS, INC.**

7968 Arjons Drive, Suite C  
San Diego, CA 92126 USA  
TEL: 858-578-2828 FAX: 858-578-2886  
E-MAIL: jenco@ix.netcom.com

**JENCO ELECTRONICS, LTD.**

PO. BOX LINKOU 117  
TAIPEI, TAIWAN  
TEL: 02 601-6191 FAX: 02 601-7206  
E-MAIL: jencoe@ms2.hinet.net

**SHANGHAI JENCO ELECTRONICS, LTD.**

18 Wang Dong Zhong Road  
Sijing Town, Songjiang  
SHANGHAI, CHINA  
TEL: (86-021)5761-9599 FAX: (86-021)5761-9598  
E-MAIL: jenco@public.sta.net.cn  
Homepage: <http://www.jenco.com.cn>