

CHEM-FEED[®]

INJECTOR



MODEL C-1100 MODEL-E

**POSITIVE DISPLACEMENT INJECTOR PUMP
OPERATING MANUAL**

TABLE OF CONTENTS

1Introduction.....**3**

2Specifications..... **3**

3Features..... **3**

4Unpacking.....**3**

5Installation**4**

5.1 ..Mounting location..... **4**

5.2. ..Input power connections... **5**

5.3 ..External input signal connections..... **6**

5.4...How to install the tubing and fittings **8**

6How to operate the Pump.....

.....**9**

6.1 ..How to adjust the output - manual stroke adjustment**9**

6.2...Electronic pump output controls **10**

6.3...Mode 0 - FVS System set-up **10**

6.4...Mode 1 - Manually Adjusting the output **13**

6.5...Mode 2 - 4-20 mA input.... **14**

6.6...Mode 3 - 0-10 VDC input. **16**

6.7...Mode 4 - Frequency (Hz) input..... **19**

6.8...Mode 5 - Pulse input (Batch) **20**

6.9...Measuring the pump output - Volumetric test.....

.....	21
7 How to maintain the Pump.....	
.....	22
7.1 ..Routine inspection and cleaning	
.....	
.....	22
7.2 ..How to clean the pump	
.....	
.....	22
7.3 ..500 hour service warning timer.....	
.....	22
Pump head and Valve exploded view drawing	
.....	23
Replacement parts drawing	
.....	
.....	24
Replacement parts list	
.....	25
Warranty information.....	
.....	26
Authorized service centers	
.....	27

1.0 Introduction

Congratulations on purchasing the C-1100 Model-E positive displacement metering pump. The C-1100 is designed to inject chemicals into piping systems and is capable of injecting against a high system pressure up to 150 PSI (10.4 bar). In addition to the front mounted mechanical flow rate adjustment, the C-1100 Model-E unit is equipped with an external input control circuitry which allows the pumps output to be externally controlled by either a 4-20mA input signal, a 0-10V DC input signal or a pulsed input signal.

2.0 Specifications

Maximum Working Pressure	150 psig / 10.4 bar (most models)
Maximum Fluid Temperature	130 F / 54C
Ambient Temperature Range	14 to 110F / -10 to 43C
Duty Cycle	Continuous
Maximum Viscosity	1,000 Centipoise
Maximum Suction Lift	up to 30 ft. water
Power Requirements	115V60Hz 80 Watts, 220V50Hz 40 Watts, 230V60Hz 45 Watts
Dimensions	6-1/4" H x 10-1/8" W x 9" D
Weight	8 lb. / 3.6 Kg

3.0 Features

- Double-ball, springless ceramic check valves with PVDF (Kynar) body, TFE/P (Aflas) and Viton o-ring seals.
- Easy access, front mounted mechanical feed rate adjustment.
- High outlet pressure capability of 150 psig (most models).
- 4000:1 adjustment turn down ratio.
- Digital electronic feed rate control.
- Corrosion proof Valox housing.
- Tamper resistant electronic control panel cover.

4.0 Unpacking

Your pump package should contain the following:

- 1 - Injector pump
- 1 - suction tube footvalve & strainer assembly
- 1 - ceramic tubing weight
- 1 - 5' Length of clear PVC suction tubing
- 1 - 5' Length of opaque LLDPE discharge tubing
- 1 - Injection fitting with internal back-flow check valve
- 1 - Mounting hardware kit

5.0 Installation

CAUTION: Proper eye and skin protection must be worn when installing and servicing the pump.

Note: All diagrams are strictly for guideline purposes only. Always consult an expert before installing the pump into specialized systems. The pump should be serviced by qualified persons only.

5.1 Mounting Location

Choose an area located near the chemical supply tank, chemical injection point and electrical supply. Although the pump is designed to withstand outdoor conditions, a cool, dry, well ventilated location is recommended. Install the pump where it can be easily serviced.

- Mount the pump to a secure surface or wall using the enclosed hardware. Wall mount to a solid surface only. Mounting to drywall with anchors is not recommended.
- Mount the pump close to the injection point. Keep the inlet (suction) and outlet (discharge) tubing as short as possible. Longer discharge tubing increases the back pressure at the pump tube.
- Your solution tank should be sturdy. Keep the tank covered to reduce fumes. Do not mount the pump directly over your tank. Chemical fumes may damage the unit. Mount the pump off to the side or at a lower level than the chemical container.
- Mounting the pump lower than the chemical container will gravity feed the chemical into the pump. This “flooded suction” installation will aid in priming the pump and will reduce output error due to increased suction lift. We recommended installing a shut-off valve, pinch clamp or other means to halt the gravity feed to the pump during servicing.
- Be sure your installation does not constitute a cross connection with the drinking water supply. Check your local plumbing codes.

INJECTOR MOUNTING

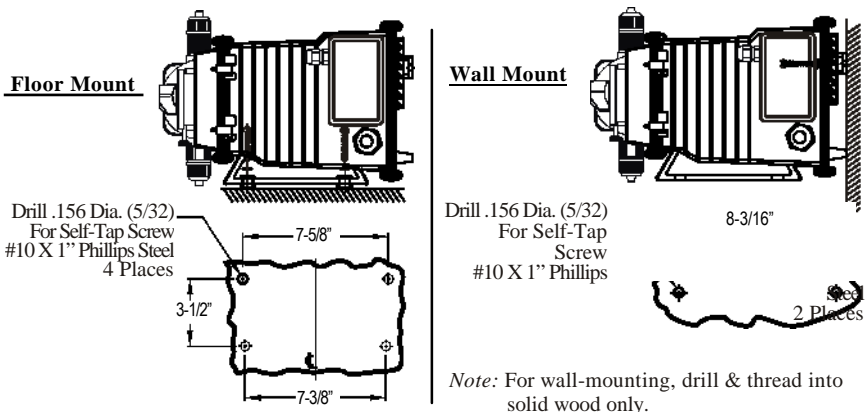

Injection / Check valve with 1/4" and 1/2" male pipe threads. Mount in upward position to prevent trapped gasses in the injection fitting.

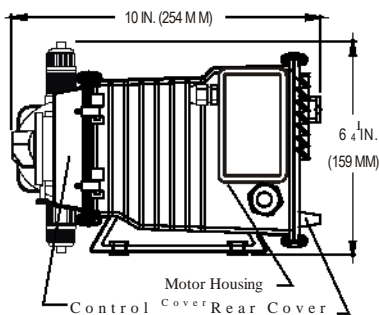
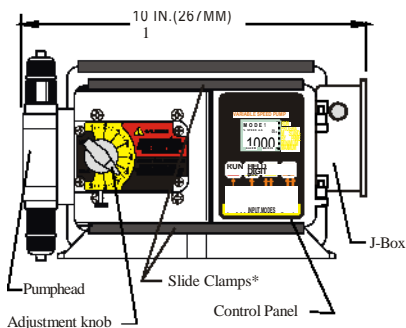
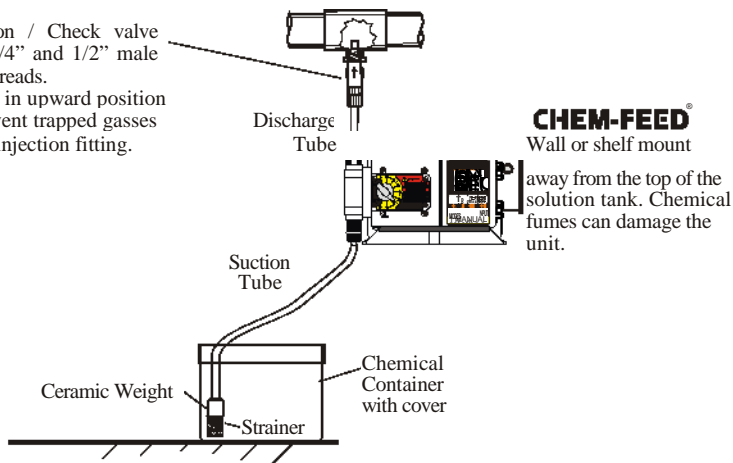

**TYPICAL INSTALLATION
PARTS LOCATOR DRAWING**

5.2 Input Power Connections

WARNING: Risk of electric shock.

- Be certain to connect the pump to the proper supply voltage. Using the incorrect voltage will damage the pump and may result in injury. The voltage requirement is printed on the pump serial label.
- Removable resistors on the circuit board are factory preset for the correct voltage. See page 7 Circuit Board Connections diagram for details.
- The pump is supplied with a ground wire conductor and a grounding type attachment plug (power cord). To reduce the risk of electric shock, be certain that the power cord is connected only to a properly grounded, grounding type receptacle.

Note: *When in doubt regarding your electrical installation, contact a licensed electrician.*

5.3 External Input Signal Connections

The pump will accept a variety of external control input signals; 4-20 mA , 0-10 VDC, TTL, CMOS, AC Sine Waves, Contact Closures, Hall Effect, NPN. The 4-20mA and 0-10 VDC loops must be powered.

All wiring connections are to be made inside of the junction box located on the side of the pump. Special connectors are not required. A liquid-tite connector is supplied and should be used for the external signal cable. The signal input wires are color coded to the type of signal being used.

SIGNAL INPUT WIRE COLOR CODES

INPUT TYPE	WIRE COLOR CODE
4-20 mA	BLUE (+) & BLACK (-)
0-10 VDC	ORANGE (+) & BLACK (-)
TTL, CMOS	WHITE (+) & BLACK (-)
CONTACT (10v @2 mAmax) HALL EFFECT, NPN	RED (+) & WHITE (-)
ALARM RELAY	PURPLE & PURPLE
FLOW VERIFICATION SENSOR	RED/WHITE (+ 20VDC) & BLACK (-) & YELLOW (signal)
MOTOR ON SIGNAL 5-20V DC open collector output closed while motor is energized	BROWN (+) & BLACK (-)

PADDLEWHEEL SENSOR SIGNAL INPUT WIRING

BLUE-WHITE PADDLEWHEEL SENSOR TYPE	PADDLEWHEEL SENSOR WIRE COLOR CODE	PUMP INPUT WIRE COLOR CODE
MODEL FH HALL EFFECT SENSOR	RED (+) BLACK (-) BARE (signal)	RED (+ 20VDC) BLACK (-) WHITE (signal)
MODEL FC AC SINE WAVE SENSOR	RED (+) BLACK (-)	WHITE (+) BLACK (-)

MOTOR LEAD WIRES

INPUT VOLTAGE	HOT LEADWIRE	NEUTRAL LEADWIRE	GROUND LEADWIRE
115V 60Hz	YELLOW	BLUE	GREEN
220V 50Hz	YELLOW	BROWN	GREEN
230V 60Hz	YELLOW	RED	GREEN

CIRCUIT BOARD CONNECTIONS

Program Disable Jumper - Located on front of Control board.
 Un-installed = enable front panel programming (default)
 Installed = disable front panel programming

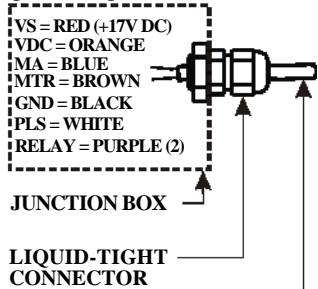
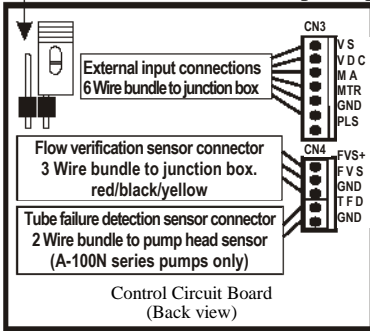

EXTERNAL INPUT CABLE
 ACCEPTABLE CABLE JACKET RANGE:
 .118 - .255 INCH . (3,0 - 6,5 MM)

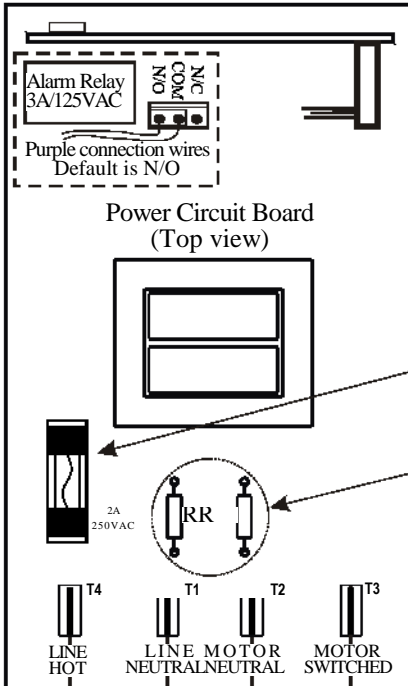

Protector Fuse
 2 Amps, 250 VoltAC
 (little Fuse #235002
 or Equivalent)

INPUT VOLTAGE RESISTOR PLACEMENT

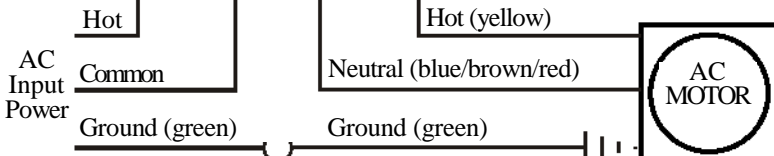
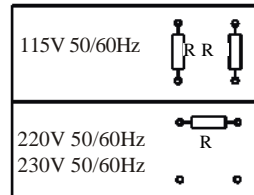

5.4 How To Install the Tubing and Fittings

CAUTION: Proper eye and skin protection must be worn when installing and servicing the pump.

- **Inlet Tubing** - Locate the inlet fitting of the pump head. Remove the tube nut. Push the clear suction tubing through the tube nut and onto the fitting barb. Hand tighten the tube nut to secure the tubing.
- **Footvalve/Strainer** - Trim the inlet end of the suction tubing so that the strainer will rest approximately two inches from the bottom of the solution tank. This will prevent sediment from clogging the strainer. Slip the ceramic weight over the end of the suction tube. Press the strainer's barbed fitting into the end of the tube. Secure the ceramic weight to the strainer. Drop the strainer into the solution tank.
- **Outlet Tubing** - Locate the outlet fitting of the pump head. Remove the tube nut. Push the opaque discharge tubing through the tube nut and onto the compression barb of the fitting. Hand tighten the tube nut to secure the tubing.

Keep outlet tube as short as possible.

- **Injection/Check Valve Fitting**
Installation - The Injection/Check valve fitting is designed to install directly into either 1/4" or 1/2" female pipe threads. This fitting will require periodic cleaning, especially when injecting fluids that calcify such as sodium hypochlorite. See section 7.0. Install the Injection/Check valve directly into the piping system. **To prevent trapped gasses, install the fitting in an upward direction.** Use Teflon thread sealing tape on the pipe threads. Push the opaque outlet (discharge) tubing through the tube nut and onto the compression barb of the Injection/Check valve fitting. Hand tighten the tube nut to secure the tubing.

FOOTVALVE/STRAINER

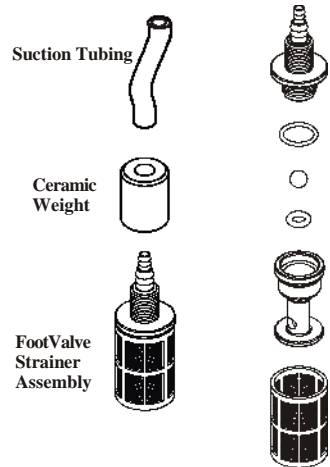

INJECTION/CHECK VALVE

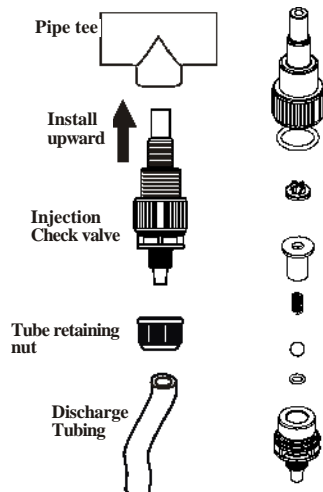

C-1100E

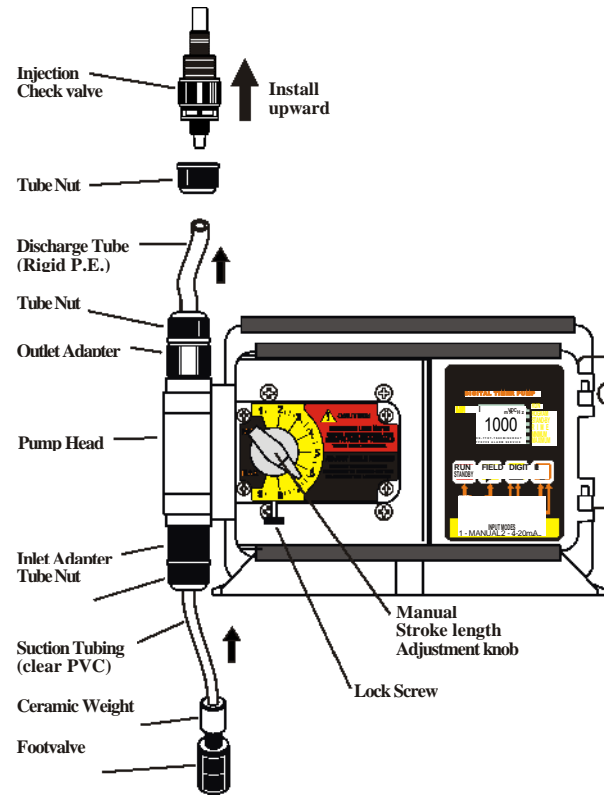

6.0 How To Operate The Pump

6.1 How to adjust the output- manual stroke adjustment

The Pump flow rate can be adjusted within a range of 5% -100% of maximum output (20:1 turndown ration) by means of a mechanical, cam type mechanism. The mechanism adjusts the pump's stroke length to an infinite number of settings within the flow range.

~ **Note:** The pump's output will reduce due to increased system pressure, increased suction lift, and increased fluid viscosity. The pump must be oversized to allow for these factors. Sizing the pump to allow adjustment within the midrange is preferred to maintain accuracy. Consult the factory for individual pump model output curve data.

To adjust the pump's output:

1. With the pump running, loosen the lock screw.
2. Turn the adjustment knob to the desired setting.
3. Re-tighten the lock screw.

6.2 Electronic Pump Output

Controls -

Open the control panel door by sliding the upper and lower slide clamps to the left.

- **RUN/STANDBY** Button -
 - Press to start and stop the pump. The **ARROW** next to the word **RUN** will light when in the run mode. The **ARROW** next to the word **STAND-BY** will blink when in the stand-by mode.
 - Press to clear **ALARM**.
 - When pressed with the **FIELD** Button, initiates a 99 second prime cycle which temporarily overrides the mode setting and runs the pump motor at 100% speed. The **ARROW** next to the word **PRIME** will blink.
 - When pressed with the **DIGIT** button, resets the 500 hour service warning timer to zero.
 - When pressed with the **MODE** button, initiates the programming mode. The **ARROW** next to the word **PROGRAM** will blink.
 - **FIELD** Button -
 - In the programming mode, selects the digit to be changed.
 - **DIGIT** Button -
 - In the programming mode, increases the selected digit.
 - When pressed with the **MODE** Button, toggles the display from operating time cycle values to input signal value.
 - **MODE** Button -
 - Used to select one of five operating modes.
- Mode 0** - FVS system set-up
Mode 1 - Manual Adjustment (external input disabled)
Mode 2 - 4-20mA input
Mode 3 - 0-10VDC input
Mode 4 - Frequency input adjusts cycle on-time
Mode 5 - Pulse input count = single batch time

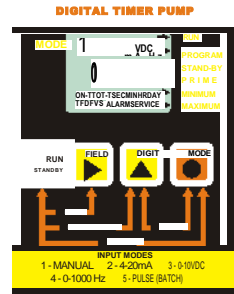

6.3 MODE 0 - FVS system set-up (sensor sold separately)

- **(FVS) Flow Verification System** The C-1100E is equipped with a

Flow Verificaion System which is designed to stop the pump and provide a contact closure output in the event the sensor does not detect chemical during pump operation. This could indicate a clogged injection fitting, empty chemical solution tank, loose tubing connection, etc.

To allow the pump to clear any gasses that may have accumulated during

stopped operation, an alarm delay time value from 1-256 seconds must be programmed (An alarm delay value of 000 seconds disables the FVS system). The pump will stop, and the alarm mode activated, if no pulses are received by the pump and the alarm delay time period has ended. Press the STAND-BY button twice to clear the alarm and restart the pump. The Flow Verification Sensor is sold as an optional accessory.

Confirm the FVS flow range - The Flow Verification Sensor (FVS) will only function within its operating range. Sensor model FV-100- 6V has an operating range of 30-300 ml/min (1-10 oz/min). If the pump’s output is less than 30 ml/min (0.5 ml/sec), the sensor will not detect chemical and a signal will not be sent to the pump.

SENSOR MODEL NUMBER	OPERATING FLOW RANGE (ml/min)
FV-100-6V	30-300
FV-200-6V	100-1000
FV-300-6V	200-2000
FV-400-6V	300-3000
FV-500-6V	500-5000
FV-600-6V	700-7000

Install the FVS Flow Sensor - The Flow Verification Sensor (FVS) should be installed on the discharge (outlet) pump head valve. The sensor includes a PVC tubing insert, located inside the sensor’s female thread connection, that is designed to seal the sensor onto the pump tube inlet adapter. Thread the sensor onto the pump tube until the tubing insert is snug against the pump tube inlet fitting - do not over-tighten. Connect the red/white, black, and white wires from the sensor to the red, black, and yellow wires located in the pump’s junction box. See page 7.

Contact Closure Alarm Output - A contact closure output (relay) is provided with the FVS system. The relay can be configured for normally

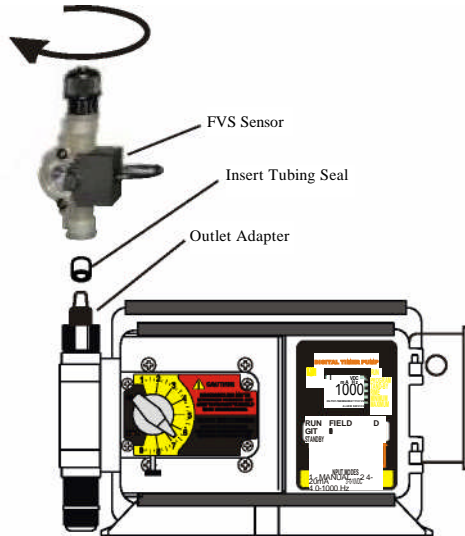

• **Enter the programming mode.** At the same time, press the RUN/STANDBY button and the MODE button. A blinking **ARROW** will point to the word **PROGRAM** indicating the program mode has been activated. The **TFD** icon will blink. (The TFD system is only used on A-100N series pumps) The word **ON** will display indicating the TFD system is activated.

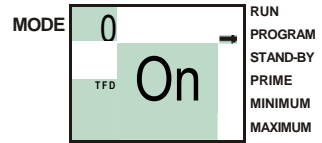

- **Press the DIGIT button to toggle the system on and off.**
- **Press the MODE button to enter the FVS system programming. The FVS icon will blink. The display will indicate the current alarm delay time setting in seconds. (000 = OFF).**

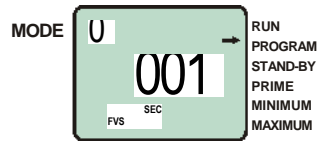

- Press the DIGIT button to set the number of seconds of alarm delay time. The number will increase to a maximum of 256 seconds and roll over to OFF.
- To exit the programming mode, press the RUN/STANDBY button and the MODE button at the same time. The arrow next to the word **PROGRAM** will disappear and an arrow will appear next to the word **RUN**.

~ **NOTE:** If while in the program mode no buttons are pressed within 60 seconds, the circuitry will automatically return to the run mode.

6.4 Mode 1 - Manually adjusting the output - In this mode, the pump is turned on and off by an electronic cycle timer. The pump will energize for the duration of the “on time” and de-energize for the remainder of the “total time” thus completing one cycle. The cycle then repeats.

The “on time” and “total time” cycles are independently adjustable from 0.1 to 199.9 units of measure with a 0.1 unit resolution. The units of measure can be seconds, minutes, hours or days.

Example: If the “total time” cycle is adjusted for 90 seconds and the “on time” portion of the cycle is adjusted for 5 seconds, the pump will run for 5 seconds and turn off for 85 seconds (90 second total cycle). This cycle is repeated until either the standby button is pressed, the cycle time is changed or the input power is disconnected from the pump.

• **Set the pump for mode 1.** Press the MODE button until **MODE 1** is shown on the LCD display.

• **Enter the programming mode.** At the same time, press the RUN/STANDBY button and the MODE button. A blinking **ARROW** will point to the word **PROGRAM** indicating the program mode has been activated. The total time **TOT-T** icon will blink. The currently

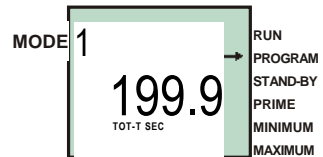

selected time unit icon will be displayed. The current total time setting will be displayed and the left most (selected) digit will blink. Note: The left most digit can be programmed from 0 - 19. The decimal is fixed and cannot be moved.

- Pressing the DIGIT button will increase the selected digit.
- Pressing the FIELD button will select a new the digit to the right or the time unit.
- Press the DIGIT button to increase the selected digit or time unit.
- Press the MODE button to exit the total time programming screen and enter the on time programming screen. The **ON-T** icon will blink. The currently selected time unit icon will be displayed. The current on time setting will be displayed and the left most (selected) digit will blink.
- Pressing the DIGIT button will increase the selected digit.
- Pressing the FIELD button will select a new the digit to the right or the time unit.
- Press the DIGIT button to increase the selected digit or time unit.
- At the same time, press the RUN/STANDBY button and the MODE button. A blinking **ARROW** will point to the word **RUN** indicating the run mode has been activated.

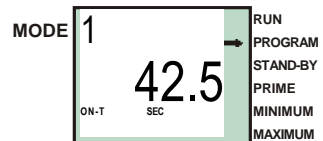

[E] NOTE: If while in the program mode no buttons are pressed within 60

seconds, the circuitry will automatically return to the run mode.

6.5 Mode 2 - 4-20 mA input - In this mode, the on-time of the cycle will automatically adjust to match the received mA input value. When the mA input value is equal the programmed maximum, the pump will run continuously.

Four values must be programmed:

- 1) **ON-T** = The amount of time the pump will run, per cycle, when the minimum mA value is received. (Typically programmed to zero)
- 2) **mA minimum** = The mA input value that will result in the on time (**ON-T**). (Typically programmed to 4 mA)
- 3) **TOT-T** = The total cycle time.
- 4) **mA maximum** = The mA input value that will result in the pump running continuously.

Example:
 ON-T setting = 0 seconds
 mA minimum setting = 4mA
 TOT-T setting = 8 seconds
 mA maximum setting = 14.8mA

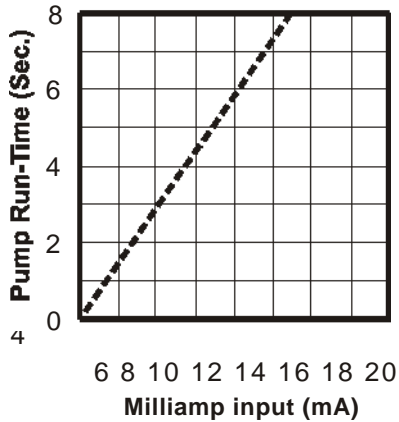

• Set the pump for mode 2. Press the MODE button until **MODE 2** is shown on the LCD display.

• Enter the programming mode. At the same time, press the RUN/STANDBY button and the MODE button. A blinking **ARROW** will point to the word **PROGRAM** indicating the program mode has been activated. The on time **ON-T** icon will blink. The currently selected time unit



icon will be displayed. The current on time setting will be displayed and the left most (selected) digit will blink. Note: The left most digit can be programmed from 0 - 19. The decimal is fixed and cannot be moved.

- Pressing the DIGIT button will increase the selected digit.
- Pressing the FIELD button will select a new the digit to the right or the time unit.
- Press the DIGIT button to increase the selected digit or time unit.

- Press the MODE button to exit the on time programming screen and enter the mA minimum programming screen. The mA icon will blink. A blinking **ARROW** will appear next to the word **MINIMUM**. The current minimum mA setting will be displayed and the left most (selected) digit will blink.

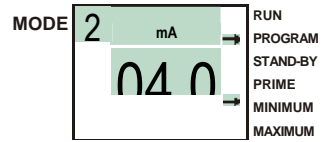

- Pressing the DIGIT button will increase the selected digit.
- Pressing the FIELD button will select a new the digit to the right.
- Press the DIGIT button to increase the selected digit.
- Press the MODE button to exit the mA minimum programming screen and enter the total time programming screen. The total time **TOT-T** icon will blink. The currently selected time unit icon will be displayed. The current total time setting will be displayed and the left most (selected) digit will blink. Note: The left most digit can be programmed from 0 - 19. The decimal is fixed and cannot be moved.

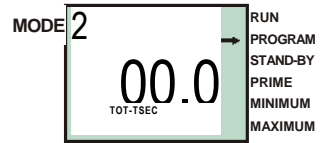

- Pressing the DIGIT button will increase the selected digit.
- Pressing the FIELD button will select a new the digit to the right or the time unit.
- Press the DIGIT button to increase the selected digit or time unit.

C-1100E

- Press the MODE button to exit the total time programming screen and enter the

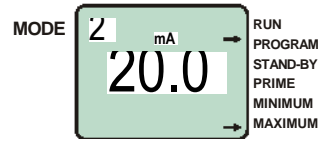

been activated.

[E NOTE: If while in the program mode no buttons are pressed within 60 seconds, the circuitry will automatically return to the run mode.

6.6 Mode 3 - 0-10V DC input - In this mode, the on-time of the cycle will automatically adjust to match the received VDC input value. When the VDC value is equal the programmed maximum, the pump will run continuously.

Four values must be programmed:

- 1) **ON-T** = The amount of time the pump will run, per cycle, when the minimum VDC value is received. (Typically programmed to zero)
- 2) **VDC minimum** = The VDC input value that will result in the on time (**ON-T**). (Typically programmed to 0 VDC)
- 3) **TOT-T** = The total cycle time.
- 4) **VDC maximum** = The VDC input value that will result in the pump running continuously.

Example:

- ON-T setting = 0 seconds
- VDC minimum setting = 0 VDC
- TOT-T setting = 6 seconds
- VDC maximum setting = 7.5 VDC

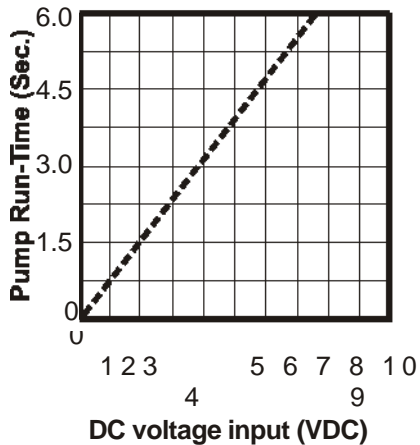

- **Set the pump for mode 3.** Press the MODE button until **MODE 3** is shown on the LCD display.

- **Enter the programming mode.** At the same time, press the RUN/STANDBY button and the MODE button. A blinking **ARROW** will point to the word **PROGRAM** indicating the program mode has been activated. The on time **ON-T** icon will blink.

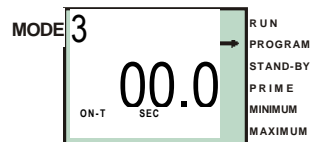

The currently selected time unit icon will be displayed. The current on time setting will be displayed and the left most (selected) digit will blink. Note: The left most digit can be programmed from 0 - 19. The decimal is fixed and cannot be moved.

- Pressing the DIGIT button will increase the selected digit.
- Pressing the FIELD button will select a new the digit to the right or the time unit.

- Press the DIGIT button to increase the selected digit or time unit.

- Press the MODE button to exit the on time programming screen and enter the VDC

E minimum programming screen. The **VDC** icon will blink. A blinking **ARROW** will appear next to the word **MINIMUM**. The current minimum VDC setting will be displayed and the left most (selected) digit will blink.

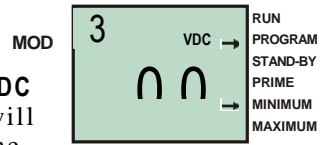

- Pressing the DIGIT button will increase the selected digit.
- Pressing the FIELD button will select a new the digit to the right.

fixed and cannot be moved.

- Pressing the DIGIT button will increase the selected digit.
- Pressing the FIELD button will select a new the digit to the right or the time unit.
- Press the DIGIT button to increase the selected digit or time unit.

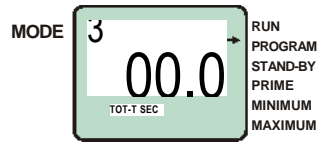

- Press the MODE button to exit the total time programming screen and enter the VDC maximum programming screen. The **VDC** icon will blink. A blinking **ARROW** will appear next to the word **MAXIMUM**. The current maximum VDC setting will be displayed and the left most (selected) digit will blink.

- Pressing the DIGIT button will increase the selected digit.
- Pressing the FIELD button will select a new the digit to the right.
- Press the DIGIT button to increase the selected digit.
- At the same time, press the RUN/STANDBY button and the MODE button. A blinking **ARROW** will point to the word **RUN** indicating the run mode has been activated.

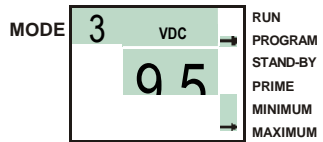

~ **NOTE:** If while in the program mode no buttons are pressed within 60

seconds, the circuitry will automatically return to the run mode.

6.7 Mode 4 - Frequency (Hz) input - In this mode, the on-time of the cycle will automatically adjust to match the received Hz input value. When the Hz value is equal the programmed maximum, the pump will run continuously.

Four values must be programmed:

- 1) **ON-T** = The amount of time the pump will run, per cycle, when the minimum hZ value is received. (Typically programmed to zero)
- 2) **Hz minimum** = The Hz input value that will result in the on time (**ON-T**). (Typically programmed to 0 Hz)
- 3) **TOT-T** = The total cycle time.
- 4) **Hz maximum** = The Hz input value that will result in the pump running continuously.

Example:

ON-T setting = 0
 seconds Hz minimum
 setting = 0 Hz TOT-T setting
 = 8 seconds
 Hz maximum setting = 425 Hz

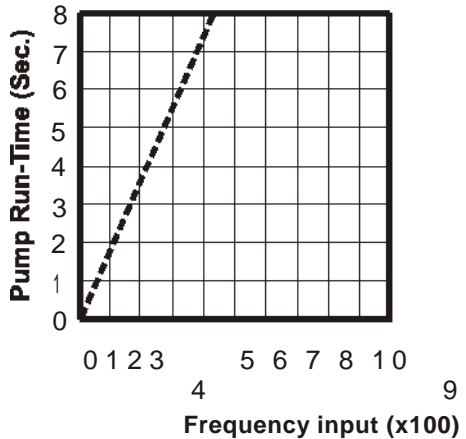

• **Set the pump for mode 4.** Press the MODE button until **MODE 4** is shown on the LCD display.

• **Enter the programming mode.** At the same time, press the RUN/STANDBY button and the MODE button. A blinking **ARROW** will point to the word **PROGRAM** indicating the program mode has been activated. The on time **ON-T** icon will blink. The currently selected time unit icon will be displayed. The current on time setting will be displayed and the left most (selected) digit will blink. Note: The left most digit can be programmed from 0 - 19. The decimal is fixed and cannot be moved.

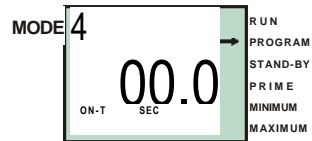

- Pressing the DIGIT button will increase the selected digit.
- Pressing the FIELD button will select a new the digit to the right or the time unit.

- Press the DIGIT button to increase the selected digit or time unit.

- Press the MODE button to exit the on time programming screen and enter the Hz minimum programming screen. The HZ icon will blink. A blinking **ARROW** will appear next to the word **MINIMUM**. The current minimum Hz setting will be displayed and the left most (selected) digit will blink.

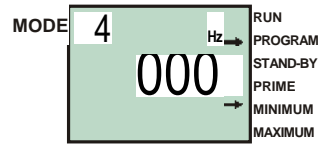

- Pressing the DIGIT button will increase the selected digit.
- Pressing the FIELD button will select a new the digit to the right.

fixed and cannot be moved.

- Pressing the DIGIT button will increase the selected digit.
- Pressing the FIELD button will select a new the digit to the right or the time unit.
- Press the DIGIT button to increase the selected digit or time unit.

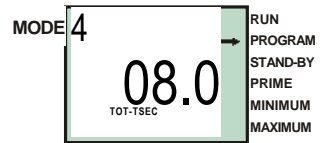

- Press the MODE button to exit the total time programming screen and enter the Hz maximum programming screen. The HZ icon will blink. A blinking **ARROW** will appear next to the word **MAXIMUM**. The current maximum Hz setting will be displayed and the left most (selected) digit will blink.
- Pressing the DIGIT button will increase the selected digit.

- Pressing the FIELD button will select a new the digit to the right.
- Press the DIGIT button to increase the selected digit.
- At the same time, press the RUN/STANDBY button and the MODE button. A blinking **ARROW** will point to the word **RUN** indicating the run mode has been activated.

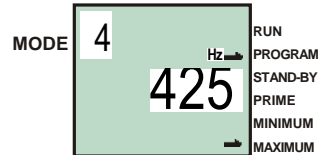

[E] NOTE: If while in the program mode no buttons are pressed within 60 seconds, the circuitry will automatically return to the run mode.

6.8 Mode 5 - Pulse input (Batch) - In this mode, when the total number of accumulated pulses is equal to the programmed pulse input value (Hz), the pump will run for the programmed on time.

Two values must be programmed:

- 1) **ON-T** = The amount of time the pump will run when accumulated pulses is equal to the programmed pulse input value (Hz).
- 2) **Hz maximum** = The number of input pulses that will trigger the batch.

● **Set the pump for mode 5.** Press the MODE button until **MODE 5** is shown on the LCD display.

● **Enter the programming mode.** At the same time, press the RUN/STANDBY button and the MODE button. A blinking **ARROW** will point to the word **PROGRAM** indicating the program mode has been activated. The on time **ON-T** icon will blink. The currently selected time unit

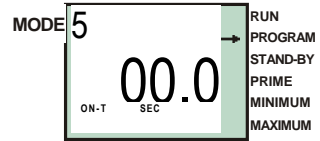

will be displayed. The current on time setting will be displayed and the left most (selected) digit will blink. Note: The left most digit can be programmed from 0 - 19. The decimal is fixed and cannot be moved.

- Pressing the DIGIT button will increase the selected digit.
- Pressing the FIELD button will select a new the digit to the right or the time unit.
- Press the DIGIT button to increase the selected digit or time unit.

● Press the MODE button to exit the on time programming screen and enter the Hz (pulses per batch) programming screen. The **Hz** icon will blink. A blinking **ARROW** will appear next to the word **MAXIMUM**. The current Hz setting will be displayed and the left most (selected) digit will blink.

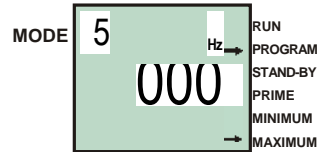

- Pressing the DIGIT button will increase the selected digit.
- Pressing the FIELD button will select a new the digit to the right.
- Press the DIGIT button to increase the selected digit.
- At the same time, press the RUN/STANDBY button and the MODE button. A blinking **ARROW** will point to the word **RUN** indicating the run mode has been activated.

~ **NOTE:** If while in the program mode no buttons are pressed within 60 seconds, the circuitry will automatically return to the run mode.

6.9 Measuring the Pump's Output - Volumetric Test.

This volumetric test will take into account individual installation factors such as line pressure, fluid viscosity, suction lift, etc. This test is the most accurate for measuring the injector's output in an individual installation.

1. Be sure the Injection Fitting and Footvalve/Strainer is clean and working properly.
2. Fill a large graduated cylinder with the solution to be injected.
3. With the pump installed under normal operating conditions, place the suction tubing with the Footvalve/Strainer installed in the graduated cylinder.
4. Run the pump until all air is removed from the suction line and the solution enters the discharge tubing. If the pump does not easily prime, remove the discharge tubing from injection fitting until the pump primes. Re-connect the discharge tubing to the injection fitting.
5. Remove the suction tubing from the graduated cylinder and refill the graduated cylinder if necessary. Note the amount of solution in the graduated cylinder.
6. Place suction tubing with the Footvalve/Strainer installed back into the graduated cylinder.
7. Run the injector for a measured amount of time. A longer testing time will produce more accurate results.
8. Remove the suction tubing from the graduated cylinder. Measure the amount of chemical injected.

7.0 How to Maintain the Pump

CAUTION: Proper eye and skin protection must be worn when installing and servicing the pump.

7.1 Routine Inspection and Maintenance

The pump requires very little maintenance. However, the pump and all accessories should be checked regularly. This is especially important when pumping chemicals. Inspect all components for signs of leaking, swelling, cracking, discoloration or corrosion. Replace worn or damaged components immediately.

Cracking, crazing, discoloration and the like during the first week of operation are signs of severe chemical attack. If this occurs, immediately remove the chemical from the pump. Determine which parts are being attacked and replace them with parts that have been manufactured using more suitable materials. The manufacturer does not assume responsibility for damage to the pump that has been caused by chemical attack.

7.2 How to Clean the Pump

The pump will require occasional cleaning, especially the Injection fitting, the Footvalve/Strainer, and the pump head valves. The frequency will depend on the type and severity of service.

Inspect and replace the pumphead valves as required.

When changing the diaphragm, the pump head chamber and pump head cover should be wiped free of any dirt and debris.

Periodically clean the injection/check valve assembly, especially when injecting fluids that calcify such as sodium hypochlorite. These lime deposits and other build ups can clog the fitting, increase the back pressure and interfere with the check valve operation. See page 8.

Periodically clean the suction strainer. See page 8.

Periodically inspect the air vents located under the motor housing and in the back on the rear housing cover. Clean if necessary.

7.3 500 Hour Service Warning Timer

The pump is equipped with a service warning timer. After approximately 500 hours of accumulated running time, the **SERVICE** icon will light. This is a reminder that the pump should be inspected and maintenance performed if necessary.

REPLACEMENT PARTS DRAWING

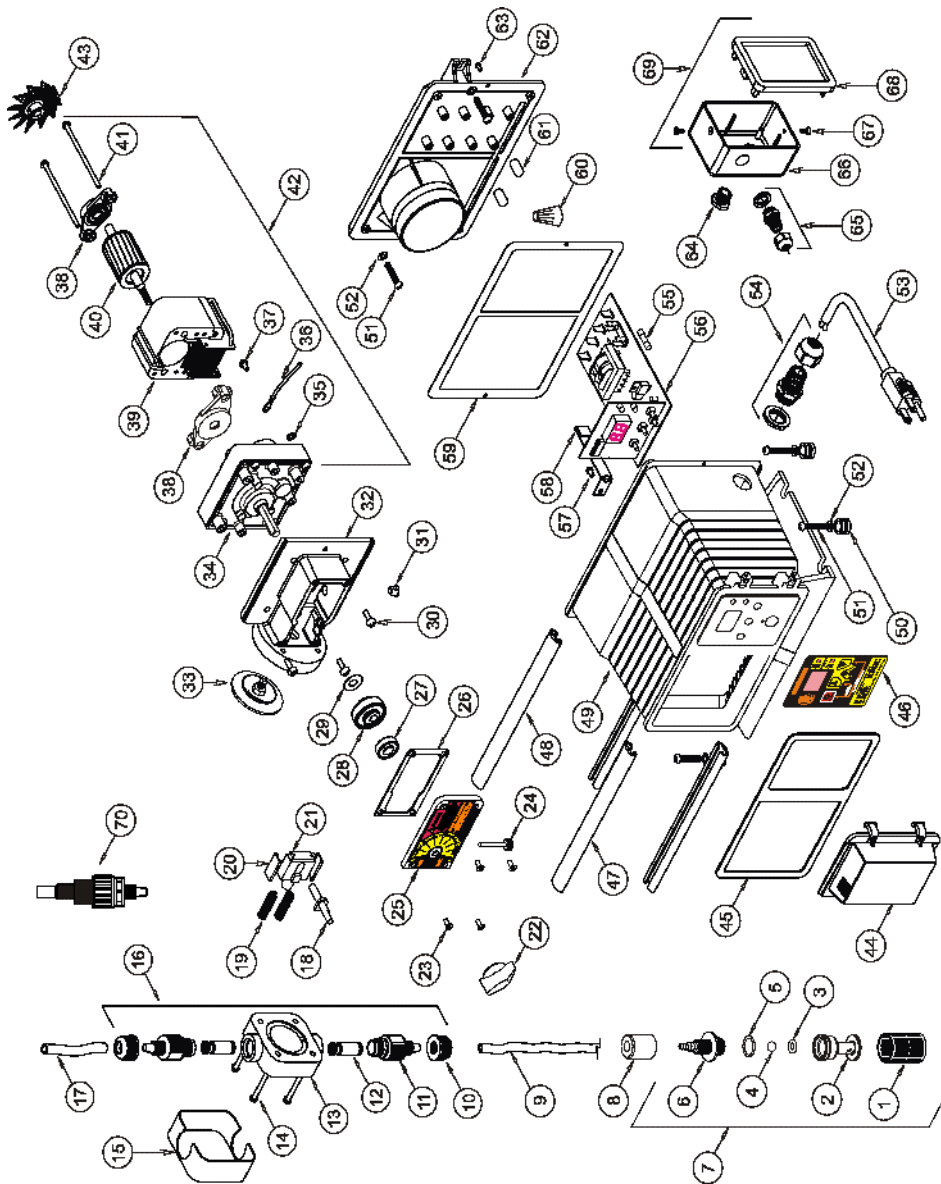

REPLACEMENT PARTS LIST

Item	Part No	Description	Qty	Item	Part No	Description	Qty	Item	Part No	Description	Qty
1	90002-086	Screen, Foot Valve, P.P	1	32	76001-183	Motor Mount, Large, Dia	1	51	90011-091	Screw, #10 X 1.0" Phil ST	6
2	90002-214	Body, Foot Valve, P.V.D.F	1	33	70000-683	Diaph. S/A 2.0 1.5N, Vtr/TFE	1	52	90011-094	Washer, #10 Stainless	6
3	90003-126	O-ring Seat, Foot Valve, Viton	1	34	70000-682	Diaph. S/A 2.0 1.5N, EP/TFE	1	53	71000-175	Power Cord, 115v60, Digital	1
4	90008-129	O-ring Seat, Foot Valve, E.P.	1		71000-357	Gearbox, 14 RPM	1		71000-176	Power Cord, 220v50, Digital	1
5	90003-014	O-ring, Foot Valve, Viton	1		71000-358	Gearbox, 30 RPM	1		71000-177	Power Cord, 230v60, Digital	1
6	90003-015	O-ring, Foot Valve, E.P.	1		71000-359	Gearbox, 45 RPM	1	54	70000-589	Connector Lig-ftic w/ nut, 3/75	1
7	90002-215	Adapter, Foot Valve, P.V.D.F	1		71000-360	Gearbox, 60 RPM	1	55	90010-223	Fuse, Digital Timer, 2a 250v	1
8	90008-068	Ceramic weight, C-346	1	35	71000-361	Gearbox, 25 RPM	1	56	72000-275	Digital Timer w/ external in	1
9	90008-116	Tubing Section 3/8 x 3 FT	1	36	71000-362	Gearbox, 120 RPM	1	57	90011-146	Screw, 8-32 X .25 Phil Pan.F	1
10	90002-077	Tube Nut, 3/7T, P.P.	2	37	90011-078	Washer, #8 Innr/Star	1	58	90006-583	Motor Retaining Clip, S8	1
11	71000-204	Adapter S/A Bullet, 3/7T Vit	2	38	90010-222	Lead Wire, ground, Green	1	59	90006-580	Gasket, Back, Neoprene	1
12	71000-205	Adapter S/A Bullet, 3/7T EP	2	39	90011-024	Screw 8-32 x .25 Hex SL ST	1	60	90010-036	Wire Nut, Blue	2
13	71000-224	Adapter S/A Bullet, 3/7T Sil	2	40	70000-028	Beating Bracket With Bearing	2	61	76001-001	Tubing Spacer, Circuit Board	2
14	71000-195	Cartridge Valve S/A, D-Ball	1	41	71000-211	Siator 115v Blue-Wh/Yell	1	62	90002-192	Enclosure Back Plate, Valox	1
15	90001-141	P/Head Noir Molded, P.P.	4	42	71000-213	Siator 220v Brown-Wh/Yell	1	63	90011-044	Screw 6-32 x .37 Swag Form	1
16	70004-074	Cover P/Head, HD logo	1		71000-212	Siator 230v Red-White/Yellow	1	64	90007-515	Bushing, J-Box Conn, Alum.	1
17	70001-153	Kit P/Head HDN 3/7T V, P-P	1		70000-027	Siator With Shaft And Spacers	1	65	90008-199	Connector Lig-ftic w/ nut, 1/87	1
18	90001-132	Offset Cam #1, 1.25"	1		70002-208	Gearmotor, 125 Rpm, 115v60	1	66	76001-168	J-Box, Ext. Input, Valox	1
19	90006-006	Return Spring	1		70002-209	Gearmotor, 250 Rpm, 115v60	1	67	90011-129	Screw, 6-32 X .25 Phil SS	2
20	90002-001	Slide Bearing	1		70002-210	Gearmotor, 14 Rpm, 220v50	1	68	71000-133	Cover, J-Box w/Gasket, Label	1
21	76000-172	Slit-rup	1		70002-211	Gearmotor, 30 Rpm, 220v50	1	69	70000-364	J-Box Assembly, Ext. Input	1
22	90002-017	Dial Knob	1		70002-212	Gearmotor, 45 Rpm, 220v50	1	70	70000-439	Inj. Valve, 5-.25 MptX.37od T	1
23	90011-168	Screw #6 x .62 PH oval 'A'	4		70002-213	Gearmotor, 60 Rpm, 220v50	1				
24	90011-121	Thumb Screw 6-32 x 1.125	1		70002-214	Gearmotor, 125 Rpm, 220v50	1				
25	71000-363	Cover Cam S/A C-1100	1		70002-215	Gearmotor, 250 Rpm, 220v50	1				
26	90006-597	Gasket, Top Cover	1		70002-216	Gearmotor, 45 Rpm, 230v60	1				
27	90004-005	Bearing, Top Cover	1		70002-217	Gearmotor, 30 Rpm, 230v60	1				
28	90012-218	Label, Cam Cover	1	43	90006-581	Fan, Motor, 2.25" Dia, Alum	1				
28	70000-131	Drive Cam S/A #1, 125"	1	44	90002-191	Door, Controls Cover	1				
	70000-132	Drive Cam S/A #2, 95"	1	45	90006-579	Gasket, Front Neoprene	1				
	70000-133	Drive Cam S/A #3, 187"	1	46	90012-216	Label Digital Timer w/ Ext.	1				
	70000-172	Drive Cam S/A #4, 180"	1	47	76000-999	Slide Clamp, Encl Front	1				
29	90011-014	Spacer, Rotor	1	48	76001-000	Slide Clamp, Encl Rear	2				
30	90011-122	Screw 1/8-32 x .50 PHL PAN	4	49	76001-169	Enclosure, Digital w/ Input	1				
31	90008-138	Plug .312 Hole Black	1	50	90003-559	Mounting Feet, Rubber	4				

LIMITED WARRANTY

Your new pump is a quality product and is warranted to be free of defects as set down in this policy. All parts, including rubberized goods, and labor are covered under warranty for 90 days from the date of purchase. Used peristaltic pump tube assemblies are not warranted. Parts, excluding rubberized goods, are covered under warranty for 12 months from the date of purchase.

Warranty coverage does not include damage to the pump that results from misuse, carelessness, abuse or alteration. Only the repair or the replacement of the pump is covered. Blue-White Industries does not assume responsibility for any other loss or damage.

Warranty status is determined by the pump's serial label and the sales invoice or receipt. The serial label must be on the pump and the pump must be accompanied by the sales invoice or receipt to obtain warranty coverage. The warranty status of the pump will be verified by Blue-White or a factory authorized service center.

Please be advised; injection and metering devices are not intended as a means of treating water to render it suitable for human consumption. When used as hypochlorinators, they are meant to destroy bacteria and algae contamination, before it's removal by filtration. Acid and soda injectors are used for PH control (balance). Blue-White injectors are factory tested with water only for pressure and performance. ***Installers and operators of these devices must be well informed and aware of the precautions to be taken when injecting various chemicals -especially those considered hazardous or dangerous.***

Should it become necessary to return an injector for repair or service, you must attach information regarding the chemical used as some residue may be present within the unit which could be a hazard to service personnel.

Blue-White Industries will not be liable for any damage that may result by the use of chemicals with their injectors and it's components. Thank you.

PROCEDURE FOR IN WARRANTY REPAIR

Carefully pack the pump to be repaired, include the foot strainer and injection/check valve fitting. Enclose a brief description of the problem as well as the original invoice or sales receipt showing the date of purchase. The receipt will be returned with the unit. Prepay all shipping costs. COD shipments will not be accepted. Warranty service must be performed by the factory or an authorized service center. Damage caused by improper packaging is the responsibility of the sender.