



Free Chlorine 4-20mA Sensors

SECTION 1.0 INTRODUCTION

1.0 FREE CHLORINE SENSOR ASSEMBLY. The Free Chlorine Sensor is shipped with the membrane cap and electrolyte separate.

1.1 Open the Bottle of Electrolyte:

- a. Electrolyte is KCl solution.
- b. After using, re-cap the electrolyte until the next use.

1.2 Membrane Cap Assembly:

- a. Remove the membrane cap from the Sensor's body as shown in FIGURE 1.
- b. Fill the membrane cap up to the top with electrolyte as show in FIGURE 2.
- c. Hold the Sensor's body vertically and screw the membrane cap onto the Sensor's body. Some electrolyte will be displaced out of the cap as shown in FIGURE 3. Screw the membrane cap until it is hand tight on the body.
- d. Rinse the Sensor with running water and wash your hands.
- e. NOTE: IF ELECTRODE IS STORED DRY OUT OF FLOW CELL AND WATER OR SALT CRYSTALS ARE SEEN ON MEMBRANE OR WHERE CAP THREADS ONTO BODY A LEAK IS PRESENT. REPLACE CAP AND ELECTROLYTE BEFORE INSTALLING INTO FLOW CELL.

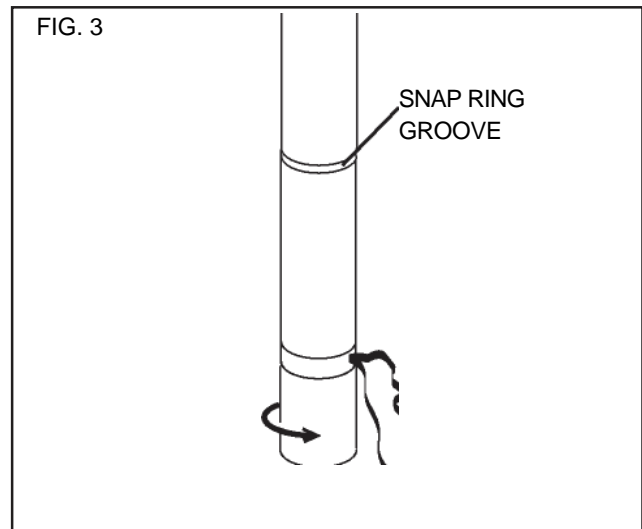
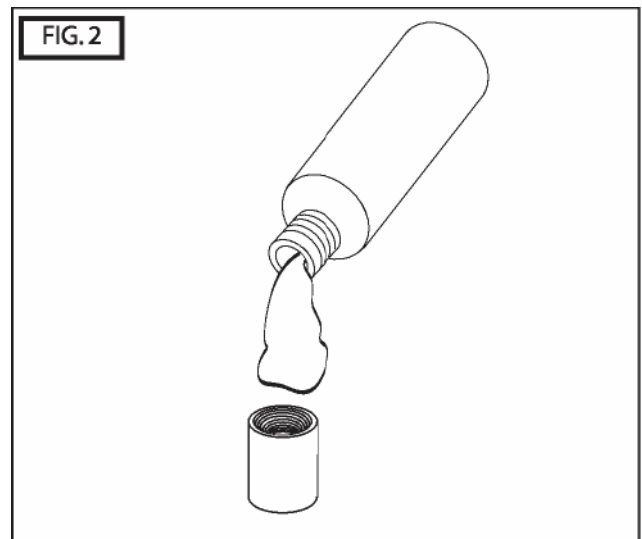
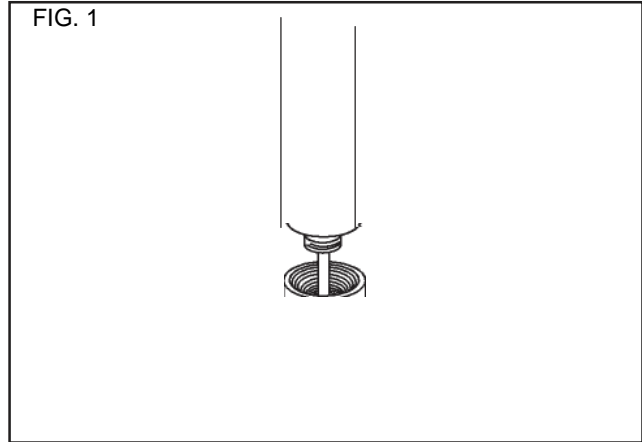

SECTION 2.0 FLOW CELL INSTALLATION

2.0 FLOW CELL. To obtain accurate Free Chlorine reading, the Sensor must be installed into the Flow Cell to prevent air bubbles formation on the membrane, proper spacing between the sensor and the installation wall, and laminar flow across the membrane.

2.1. Using two 3/4" NPT Tube/pipe fittings or pipe nipples, connect the Flow Cell into your system, noting the inlet and outlet orientation. INLET SIDE is side of flow cell with thin tube (see FIGURE 4)

SECTION 3.0 SENSOR INSTALLATION

3.0 SENSOR INSTALLATION INTO FLOW CELL.

- a. First install threaded fitting onto sensor body (remove fitting if pre-installed in flow cell)
- b. Next, slide o-ring onto body of sensor until it reaches bottom of threaded fitting.
- c. Install snap-ring into groove on sensor body
- d. Thread sensor assembly into top of flow cell as shown in FIGURE 4.
- e. Turn on flow and verify the flow through the Flow Cell is at least 30liters/hour (0.15 gpm) and no more than 100 liters/hour.
- f. If a large bubble or pocket of air is seen in the narrow vertical tube on the inlet side of the flow cell, loosen 1/2-30 hex nut at top with 1/4" hex wrench to release.
MAKE SURE TO TIGHTEN NUT BEFORE FLOW IS STARTED AGAIN.

SECTION 4.0 ELECTRICAL INSTALLATION

4.0 ELECTRICAL INSTALLATION. The sensor produces an approximate output of 4-5mA in air and 15-20mA at the top range of free chlorine output (0-2ppm, 0-10ppm).

NOTE: The supply voltage to the Sensor must be 12-24 V DC with minimum of 50 mA. Maximum load is 1 Watt. The Sensor is not electrically isolated. All other elements of the system must be electrically isolated. The controller/monitor must be isolated from the Sensor and the supply voltage.

The sensor has 3 wires, red (+) , black (-) and clear (shield). Twist together or solder black and clear if instrument does not have separate ground. If a separate ground is available such as for PLC's connect clear (shield) to it.

Attach the red wire to the power supply positive terminal (+)and the black wire to the PLC or DVM positive (+) terminal. Connect a wire (customer supplied) from the power supply negative (-) and the PLC or DVM (-). See FIG 4a. The Sensor will require several minutes to stabilize after power is supplied to the Sensor.

SECTION 5.0 SENSOR CONDITIONING

5.0 SENSOR CONDITIONING The sensor requires conditioning prior to generating stable values.

- a. For new Sensors, allow the Sensor to run overnight before calibration.
- b. If the Sensor will be un-powered for 2 hours or more, run for 3 hours prior to use.
- c. After membrane/electrolyte replacement, allow the Sensor to run for one hour.

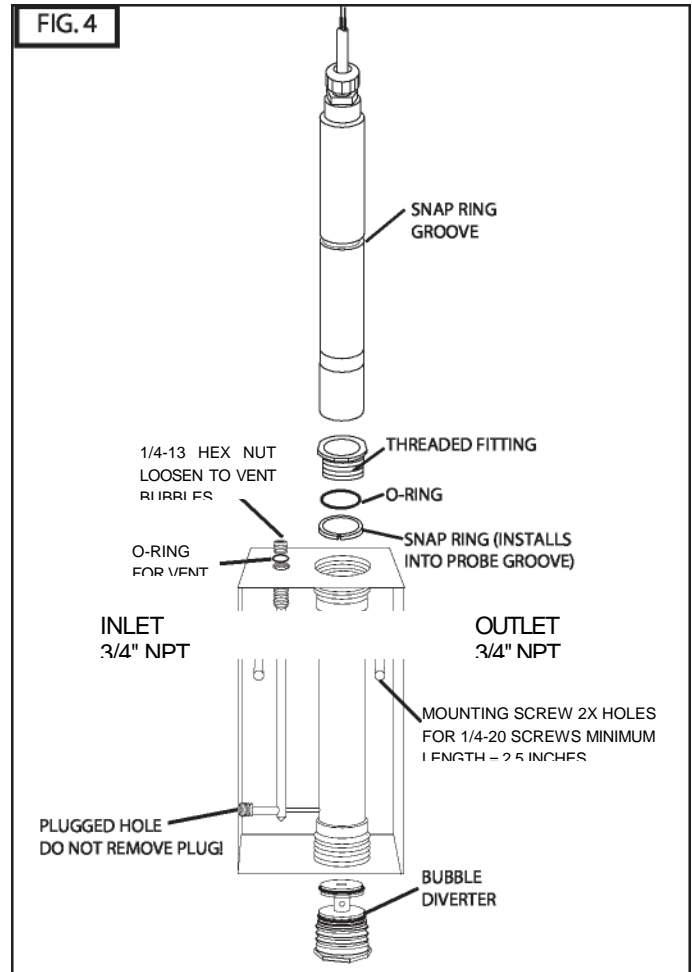

SECTION 6.0 CALIBRATION

6.1 Zero point calibration:

- Complete the stabilization of the Sensor before calibration.
- Insert the Sensor into a beaker of clean water (must be free of ozone and chlorine).
- Stir the Sensor until the measured value is stable for 5 minutes (FIGURE 5).
- Calibrate the controller/monitor to zero in accordance with the instrument operating instructions.
- Replace the Sensor into the Flow Cell per SECTION 3.0.

6.2 Slope Calibration:

- Determine the free chlorine content using a diethyl-p-phenylenediamine (DPD) colorimeter test kit (see FIGURE 6.), Not included with ClO₂ sensor and flow cell.
- Measure Free Chlorine content with sensor. Make sure that calibration flow rate matches flow rate when measuring sample since probe output is flow rate dependent. Make sure pH is within 5.5-8.0 range.
- Repeat this slope calibration after one day.
- Routinely repeat the slope calibration once a month.

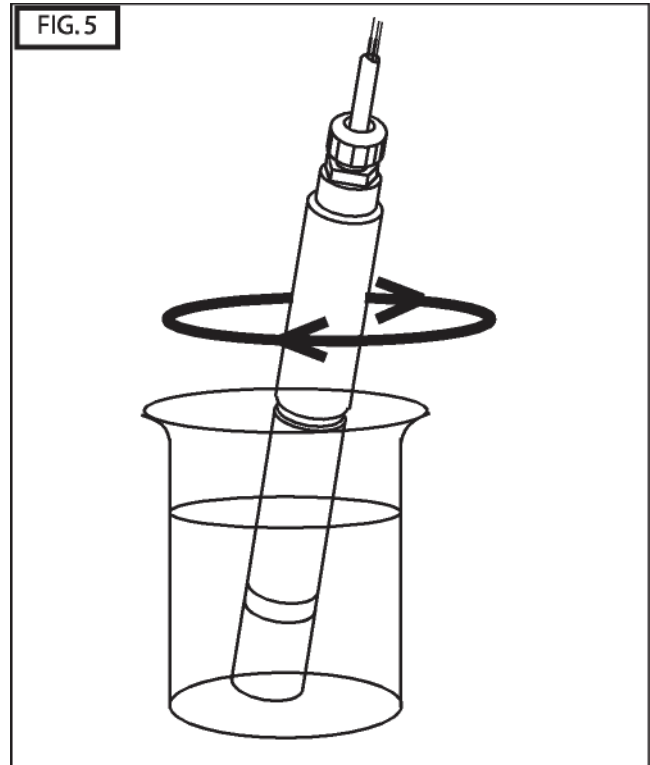

FIG. 5

SECTION 7.0

SENSOR STORAGE

7.0 STORAGE. Store sensor at 5oC- 50oC ONLY.

- Short Term Storage (1 week or less): Store in Flow cell with water to prevent the probe from drying.
- Intermediate Term (1 week to 1 month): Store in cap, bottle, or beaker with water to keep membrane wet.
- Long Term (1 month or longer): Remove Membrane Cap, rinse cap and electrodes with distilled or deionized water. Allow to dry. Loosely screw cap onto Sensor (do not screw on cap so that it stretches the membrane).

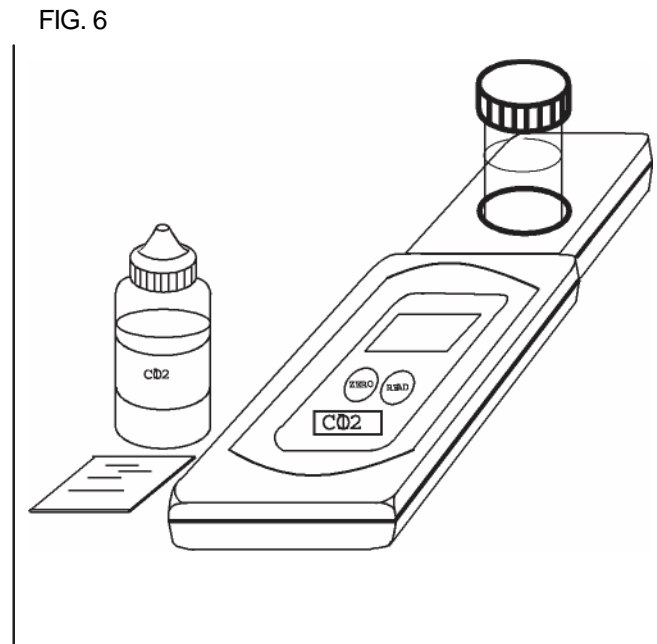

FIG. 6

SECTION 8.0
SENSOR MAINTENANCE/
RECONDITIONING

8.0 MEMBRANE REPLACEMENT. If membrane replacement is required, a new cap with preinstalled membrane must be used. Order FCL Cap/membrane replacement. Follow directions in SECTION 1.0 for re-assembly of the sensor.

SPECIFICATIONS

| | |
|-------------------------------|---|
| Operating temperature range: | 5-45 degC |
| Storage Temperature range: | 5-50 deg C |
| Operating pressure range: | 1 bar/ 14.5 psi/1atm |
| Flow rate minimum: | 20 liters/hr (.09 gpm) |
| Flow rate maximum: | 100 liters/hr (.44 gpm) |
| Wetted Materials: | acrylic, PTFE, Nylon, PVC, Buna-N |
| pH range: | 5.5-8.0 |
| Conductivity of Water Sample: | 50-10,000 uS/cm |
| Output signal: | 4.5+/- 0.5mA in air (zero) 15-20mA at high range (2 or 10ppm) |
| Power Requirement: | 12-24 Vdc, 50 mA minimum |
| Cross-Sensitivity: | di-/trichloramine, iodine, ClO ₂ , ozone, bromine and bromamine |

PHORP

A Division of Pathfinder Instruments, LLC

2075 Corte Del Nogal, Suite X , Carlsbad, Ca 92011

PH: 800-284-9698 / 760-438-08909 / FAX: 760-438-3953

EMAILS: info@phorp.com
info@pathfinderinstruments.com