

Operating Manual

Model SK-252



pH/ORP Controller

Table of Contents

1. General Description

2. Specifications

3. Installation

- A. First Things
- B. Mounting
- C. Wiring Power to Controllers
- D. How to Connect Pumps or Solenoids
- E. Figure 1 - Wiring Diagram
- F. Dimensions & Cutout

4. Operation

- A. Figure 2 - Front Panel
- B. Key Pad Operation
- C. Programming
 - 1. How to Change the Set Point
 - 2. How to Program the control action
 - 3. How to Program Hysteresis

5. Calibration

- A. pH Calibration
- B. ORP Calibration

1. GENERAL DESCRIPTION

The Model SK-252 is a 1/16 DIN microprocessor based, on-off controller for pH or ORP. It accepts any combination electrode for an input and has a relay, or SSR, or 4-20mA control signal for an output. All functions are programmable from the front panel, programmed values remain in memory when the power is turned off. Dual digital displays indicate the process value (pH or ORP) and the control set point. The process value is displayed in RED and the set point in GREEN. The power supply is universal and operates on 100 to 240VAC, 50/60Hz. Automatic temperature compensation terminals on the pH controller allow this to be performed with a 1000 ohm pt sensor, or manual with fixed resistors.

2. SPECIFICATIONS

| | | |
|----------------------------------|---|------------------|
| Model..... | SK-252-pH..... | SK-252-ORP |
| Range..... | 0 to14.00pH..... | -1000 to +1000mV |
| Resolution..... | .01 pH..... | 1 mV |
| Accuracy..... | ± .2pH..... | ± 0.2% of span |
| Dead band..... | Front panel adjustable 0 to 50% of span | |
| Main Output Relay..... | S. P. D. T. Relay 3 Amp @ 115VAC , Resistive Load | |
| Power..... | 100 to 240 VAC 50/60 Hz @ 3Watts | |
| Operating temperature range..... | -10 to +50°C | |
| Storage temperature range..... | -20 to +60°C | |
| Display..... | 4 Digit red LEDs (pH, ORP), 4 Digit green LED's (Set Point) | |
| Dimensions..... | 48 x 48 x 78.8 mm (1/16 DIN) | |
| Memory..... | Non - volatile | |

3. INSTALLATION

A. First Things

Upon receiving your order of **SK-252** controller check to verify that the part number and quantities agree with the enclosed packing slip. If any discrepancies exist, be sure to contact **Pathfinder Instruments** immediately.

Inspect all controllers for damage. Check for damaged boxes, scratches on the controller's enclosures and face plates, or any damage that may exist due to improper handling. If such a case exists save the shipping carton and shipping material, and contact your shipping agent immediately.

B. Mounting

To flush mount your controller, first verify that the depth of your cabinet will accommodate the length of your instruments. Also verify that where the controllers are to be mounted there are no corrosive gasses present and no vibration, impact, water, or extreme temperature exposure. Once verified, follow the diagrams below and cut the correct sized hole from the cabinet's panel; the panel should be between 1 and 8 millimeters thick. Insert each unit through the front of the panel. the controller's bezel should catch and not feed through the cut out. When the controller is properly fitted in the panel, slide the plastic mounting clamp in place and tighten the clamp screws for a firm fit.

C. Wiring Power to Controllers

AC power is to be connected to the power input terminals located on the back of your **SK-252**, refer to the wiring diagram in the manual or on the side of the controller for the correct terminals. Your power connections should be made with 18 gauge or larger insulated wire. A 3 amp fuse should be connected in series with power and your controller to help eliminate any problems which could occur due to an over current situation. The **SK-252's** unique power supply circuit, incorporating a free voltage transformer accepts line voltages between 100 and 240 VAC; no need to change your wiring to accommodate voltage differences within the rated voltage range.

D. How to Connect Pumps or Solenoids

The main control relay is programmed to turn on when the input is above the set point, for a pH control application wire an (**ACID** for pH, **REDUCTION** for ORP) pump or solenoid to the **normally open contact**, wire the **power** voltage to the **common contact**. For (ALKALINE pumping,oxidation for ORP), change the control action so that the relay actuates below the set point as described in the programming section.

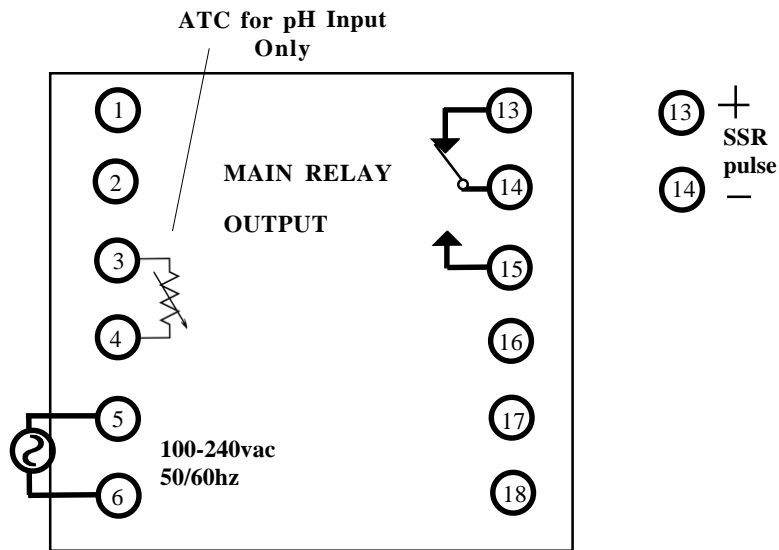

wiring diagram

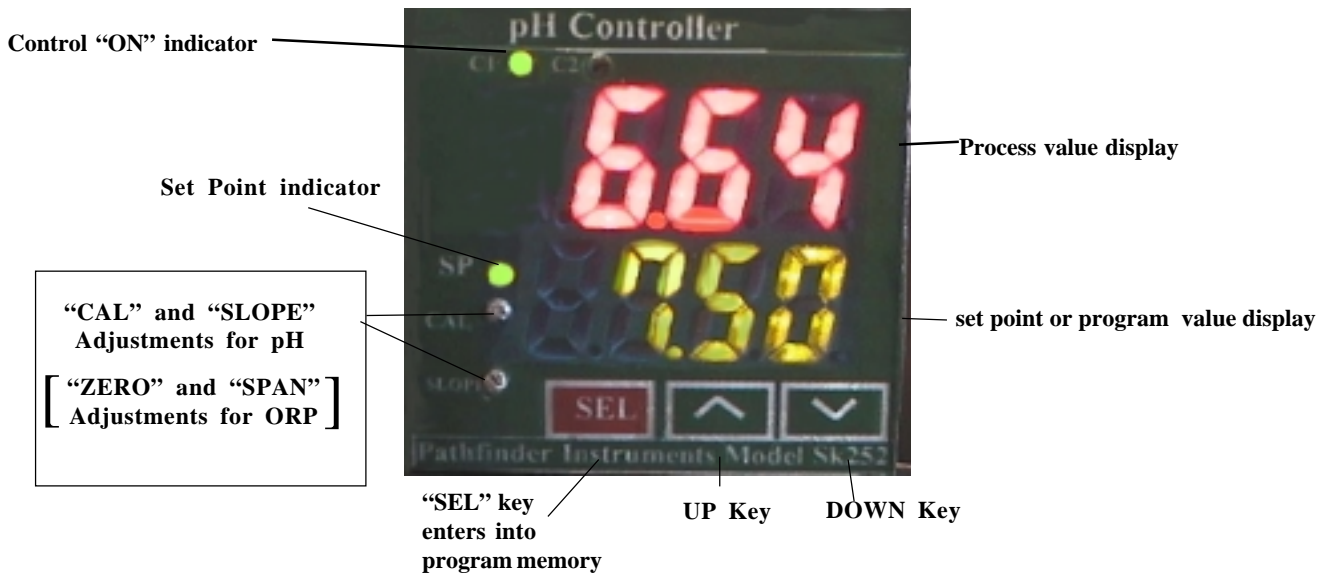
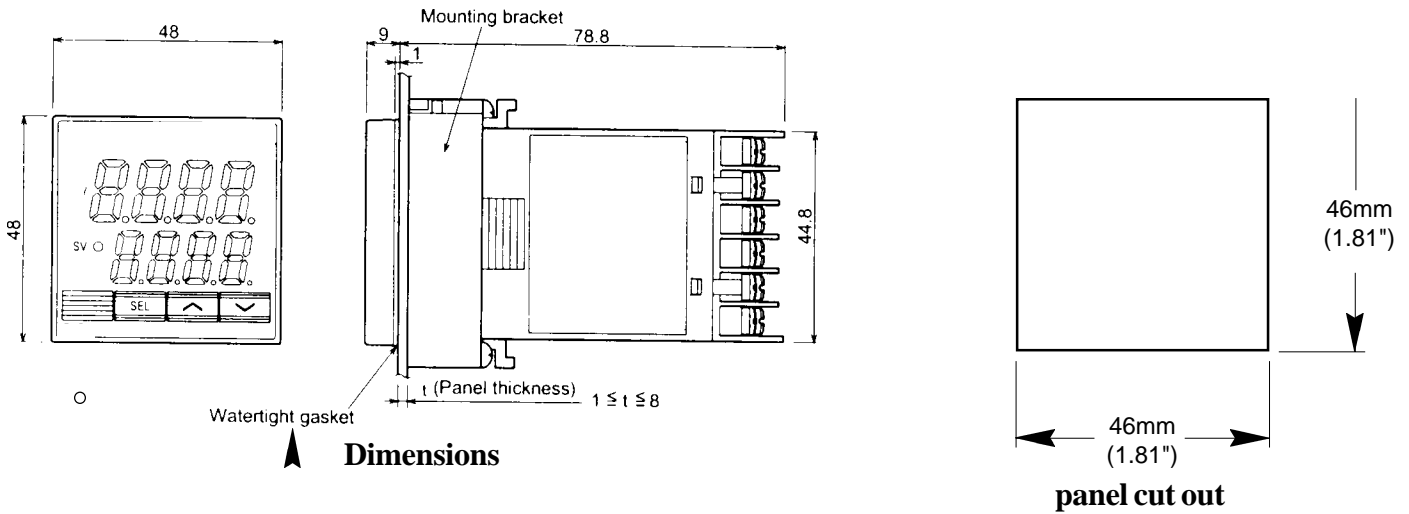

Front Panel

4. Operation

B. Keypad Operation

1. "SEL" key; changes upper display to the first programming menu, advances the display through the menu and sets the programmed information into memory
2. "\^" up arrow key, increases value displayed in the green (lower) display
3. "\v" down arrow key, decreases value displayed in the green (lower) display
4. Press and hold "SEL" key for approximately 3 seconds and "HYS" will appear in the upper display. Hold the "SEL" key for approximately 6 seconds and P-n1 will appear

C. Programming

1. How to change the set point

Press and hold the "\^" up or "\v" down arrow until the correct number appears, the new set point will be active after 5 seconds.

2. How to change the control action (Relay activates above or below the set point)

Hold the "SEL" key for approximately 6 seconds and "P-n1" will appear in the upper display, the control code will appear in the lower display, "0" or "1" will actuate **below** the set point, "2" or "3" will actuate **above** the set point. Press the "SEL" switch once, the value will flash, change the value with the "up" or "down" keys, and press the "SEL" key again to set it in memory. Holding the "SEL" key for approximately 2 seconds will return to normal operation.

3. How to program Hysteresis

Hold the "SEL" key for approximately 3 seconds and "HYS" will appear in the upper display, the hysteresis amount will appear in the lower display, press the "SEL" key once and the amount will flash, change the amount to the desired value with the "up" or "down" keys, press "SEL" again to set it in memory. Holding the "SEL" key for approximately 2 seconds will return to normal operation.

5. Calibration

A. How to calibrate pH

The front panel has two adjustments labeled "CAL" and "SLOPE", always adjust the CAL first. Place the pH electrode in a # 7.00 buffer solution wait for the reading to stabilize and adjust the CAL for 7.00. Rinse the electrode and place it in a # 4.00 buffer solution, wait for the reading to stabilize and adjust the SLOPE for a reading of 4.00. Calibration complete.

B. How to calibrate ORP

The front panel has two adjustments labeled "ZERO" and "SPAN", the ORP controller can be calibrated with a millivolt source substituted for a probe.

Short the input connector and adjust the ZERO adjustment for a reading of 0000. Apply +500 mV from an accurate millivolt source and adjust the SPAN adjustment for a reading of 0500.

To verify the accuracy of the ORP probe an ORP calibration kit is available from **PATHFINDER INSTRUMENTS**, it consists of enough materials to do 30 tests, it contains reagents, stirrers, beakers and instructions. It costs \$40, ask for stock # B-125.