



Operating Manual

Model SK-631

pH /ORP Controller



2075 Corte Del Nogal Suite X
Carlsbad, Ca 92009
Phone (760) 438-0890
Fax (760) 438-3953

1.General Description

The Model 631-420 pH is a microprocessor programmable controller that accepts any combination pH electrode as an input. Output is a 3 amp relay with on off control that can be programmed to operate above or below the set point for control of acid or base.

The power source is from 85 to 265 VAC, 50/ 60Hz free voltage there is no need to change connections for different voltages.

The controller is programmable from the front panel via 8 switches, and calibration is done using two front panel adjustment pots.(see programming instructions in the following pages)

The front panel is NEMA 4X rated and mounting hardware is provided.

Specifications:

Input:.....pH combination electrode

Input Range:.....0 to 14 pH

Accuracy:.....+/- 0.1pH units

Control output.....(1) 3A SPDT relay

Recorder output.....4 to 20mA

Front panel.....NEMA-4X rated

Panel cutout.....92 X 92 mm (1/4 DIN)

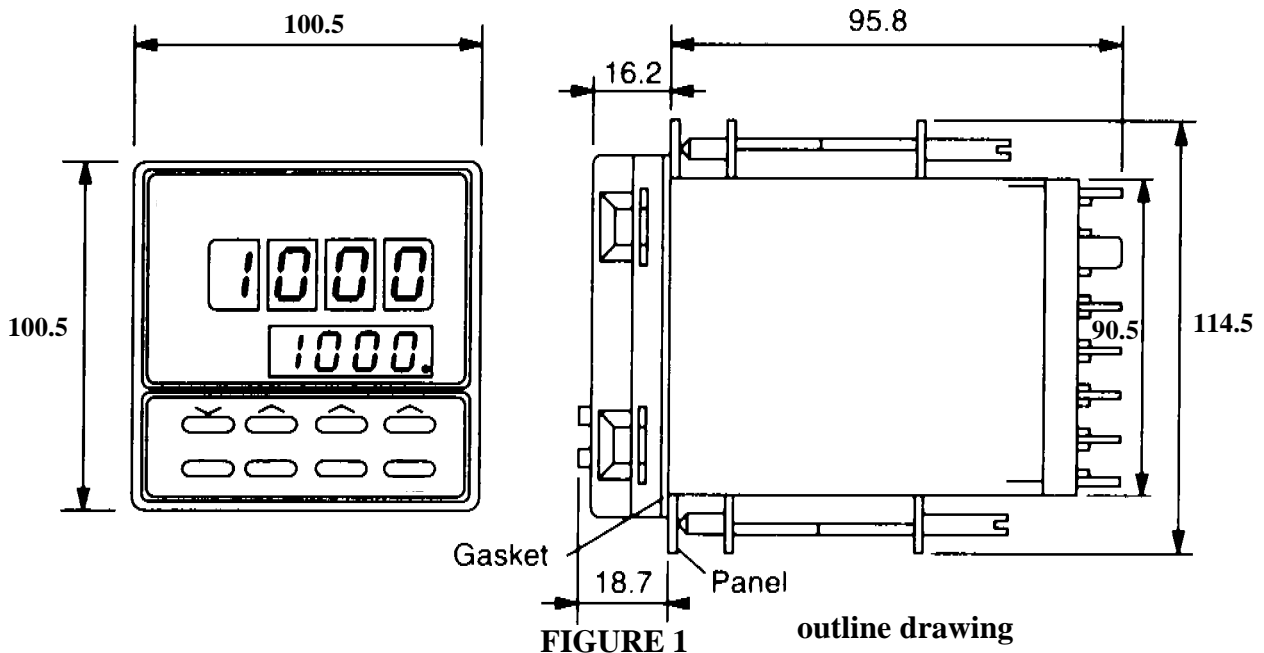
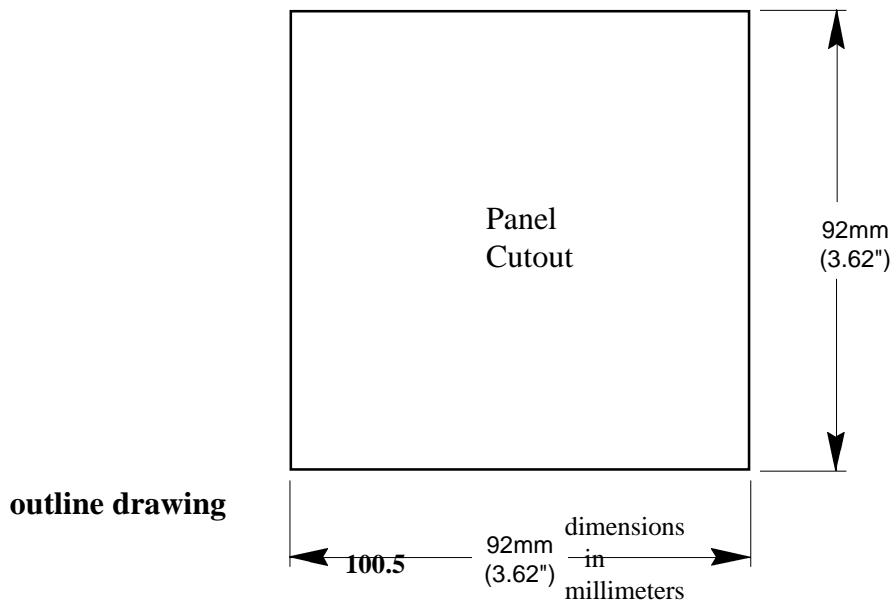

2. INSTALLATION

A. First Things

Upon receiving your order of SK631 Controller Check to verify that all part numbers and quantities agree with the enclosed packing slip. If any discrepancies exist, be sure to contact your supplier immediately.

Inspect all controllers for damage. Check for damaged storage boxes, scratches on the controller's enclosures and face plates, or any other irregularities that may exist due to improper handling. If such a case exists save the shipping boxes and shipping material, and contact your shipping agent immediately.

B. Mounting

To flush panel mount your controller, first verify that the depth of your cabinet will accommodate the length of your instruments. Also, verify that where the controllers are to be mounted there is no corrosive gases (sulfuric gas, ammonia, etc.) present and no vibration, impact, water, or extreme temperature exposure. Once verified, follow the diagrams below and cut appropriately sized hole from the cabinet's panel; the panel should be between 1 and 8 millimeters thick. Insert each unit through the front of the panel. The controller's bezel should catch and not feed through the cut-out.

If the fit seems too tight, insert the outer case alone, mount, then insert the rest of the controller inside the mounted case. Clip each of two metal, screw-type mounting brackets, two are shipped with every SK631 unit, to the top and bottom of your controller. The mounting bracket's tabs fit into the two holes on both the top and bottom of the controller's outer case. With an instrument screwdriver, turn the screw in the mounting bracket until the end of it touches the back of the panel; do this to both brackets. Making sure the face of the controller is flush and straight, tighten both mounting bracket screws. Your controller should now be firmly set. If the controller still loose, however, tighten the mounting bracket screws a little more; do not use excessive force. Do this to each controller you want mounted. Your controllers are now ready to be wired.

C. Wiring Power to Controllers

AC power is to be connected to the power supply input terminals located on the back of your SK631 consult the wiring diagram above for the correct terminals. Your power connections should be made with 20 gauge or larger insulated wire. A 3 AMP fuse should be connected in series with power and your controller to help eliminated any problems which could occur due to an over-current situation. Spade connectors may be used to facilitate the connection of the power supply wires to the power supply input terminals. The SK631's unique power supply circuit, incorporating a free voltage transformer, accepts line voltages between 85 and 264 VAC; no need to change your wiring to accommodate voltage differences within the rated voltage range. Screw down your terminals securely. Tape or otherwise insulate your connections making sure that there is no exposed wire which could cause a dangerous short across your controller. Do not apply power to your controller until all other wiring connections have been made.

In order to minimize the risk of high frequency noise induced by coils and windings in relays, solenoids, and transformers, twist the power supply wires and keep them separated from the input and output wires also connected to your controller. A line filter or power conditioner connected to the input power will aid in protecting your controller from the effects of spikes and power transients.

SK631 WIRING DIAGRAM

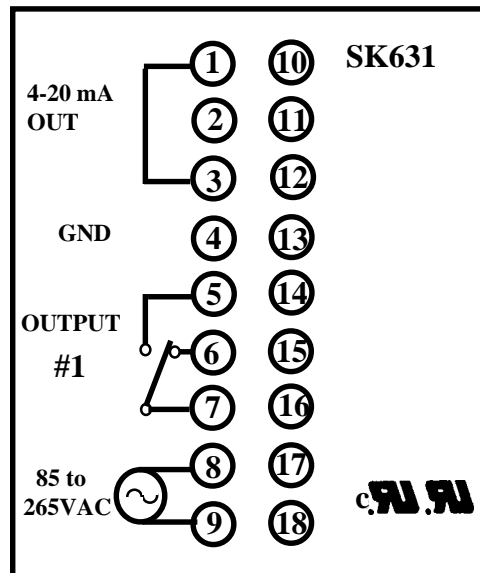

3. OPERATION

FRONT PANEL DESCRIPTION

PH DISPLAY	4 digit 7 segment red LED display 00.00 to 14.00 for pH
SET POINT DISPLAY	4 digit 7 segment green LED display Set point status LED indicates when the SK631 is indicating the Main Set point.
C1 INDICATOR	Control Output #1 energized when output #1 is on.
∨ KEY	Decrement key (data value decreased one digit every time key is pressed).
∧ KEYS (1,10,100)	Up DIGIT keys (these keys enable a digit change the first time pressed the digit will flash) flashing digit will increase every time the keys are pressed.
"S/P" Set Point Key	Set point is displayed and menu is reset when pressed.
"SEL" select Key	Used to select parameters in the controllers menus, changes menus when held for 10 seconds.
"DATA" Data Key	Displays the values programmed for each parameter selected.
"ENT" Enter Key	Saves the parameter data in the controllers memory.

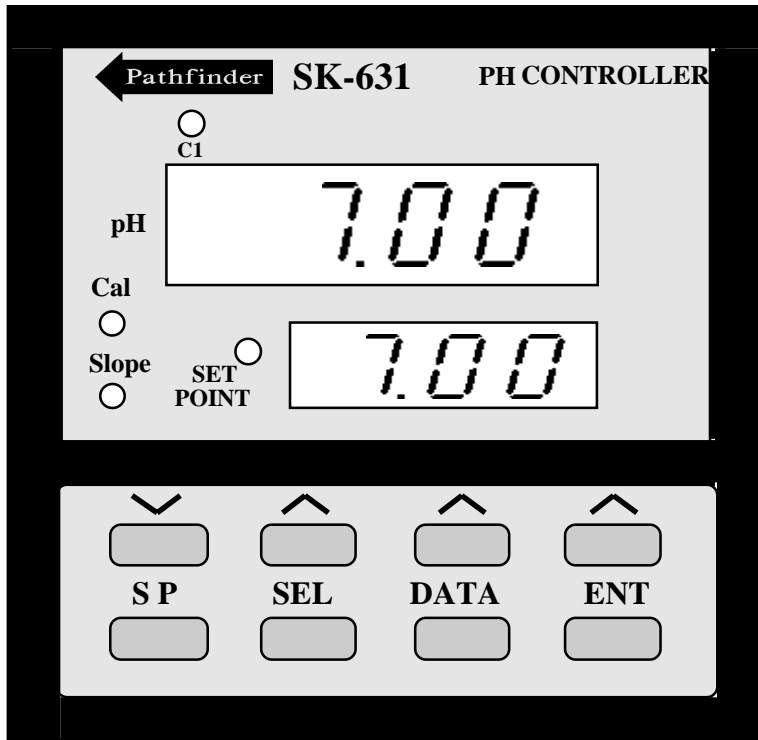

Figure 2

4. PROGRAMMING

How to Change the Set Point

1. Press "S/P"
2. Press ∧ under the digit you want to change, the digit will flash on and off meaning it's ready to be changed.
3. Press ∨ or ∧ to increment or decrement the digit, when it's at the number you want press "ENT", this puts it into memory.
4. Repeat step 2 and 3 for all the digits that you want to change.

PROGRAMMING (continued)

How to Change From Primary to Secondary Menu

1. Press and release "SEL" key, "hys" will appear in set point display.
2. Press and hold "SEL" key for 5 to 10 seconds until "P-n1" appears.
3. Controller is now in the secondary menu.
4. To return the primary menu, press and hold "SEL" key for 5 to 10 seconds until the primary menu appears in the Set Point Display.
5. To return to the Main Set Point Display press the "S/P" key.

How to Program the hysteresis or dead band

1. Press "SEL" key, "hys" will appear in Set Point Display.
2. Press "DATA" key, the hysteresis is shown, (initially set to .14).
3. Press \wedge to enable a DIGIT, change data with up \wedge or down \vee key to change the amount of hysteresis
4. After changing the hysteresis setting Press "ENT" key to set it in memory

How to Program the Control action for "Acid" or "Base"

1. Press "SEL" key, "hys" will appear in the Set Point Display.
2. Press and hold "SEL" key for 5 to 10 Seconds, "P-n1" will appear.
3. A setting of "0" or "1" in the P-n1 position is for adding BASE, the control output will be on below the set point, a setting of "2" or "3" in this position is for adding ACID, the control output will be on above the set point
4. Press "DATA", press \wedge to enable DIGIT, change data with up \wedge or down \vee key to code "1" or "2" .
5. Press "ENT" key to set it in memory

5. CALIBRATION

How to Calibrate pH

A. Calibration for pH is done by the front panel adjustments marked "CAL" and "SLOPE". Always adjust the "CAL" first and then the "SLOPE".

B. Procedure

1. Connect the pH probe to the SK631
2. Place the probe in a #7.00 buffer solution. Adjust the "CAL" for a reading of 7.00 pH.
3. Remove and rinse the probe in tap water.
4. Place the probe in a #4.00 or a #10.00 buffer depending on the instrument usage. (Acid or Base) Adjust the "SLOPE" for a reading of 4.00 or 10.00.
5. Calibration Complete.